

INDUCTION MOTORS

FRAME 63 TO 355

LOW TENSION TEFC & SPDP INDUCTION MOTORS



Energy Efficient Motors

INDUCTION MOTORS

INDUCTION MOTORS

Dear Customer,

In pursuance of the culture of continuous improvement towards customer satisfaction, we have now incorporated the latest designs for our range of LT AC motors ensuring better electrical performance as well as versatility in mechanical features. The standard motors offered are in compliance with efficiency level 2 of the proposed revision to IS12615 in India as well as CEMEP standards prevalent in Europe for Energy Efficient Motors. These features have given the necessary impetus to the long cherished ambition of being a global player in the motor industry by being comparable to the best in the world in terms of performance. We take great pleasure in issuing this booklet with the detailed information.

LT Motors division designs & manufactures a multifirmity of Electric Motors (DC & AC) and Alternators with manufacturing

units at Ahmednagar & Goa. This division, which is part of the CG Industrial Systems SBU, has a dedicated team of professionals and state-of-the-art technology providing reliable and trouble free products and services on the basis of superior mechanical & product design.

The company's operations include R&D, manufacturing, marketing and turnkey projects in clearly defined Core Business Areas, at home and overseas. Over the last six decades, unparalleled growth has seen CG emerge as a professionally managed organisation with a workforce of over 6500 employees including more than 2500 professionals. With 23 manufacturing units and Centralized Support Services, CG offers a comprehensive and multi-faceted product range nationally through strategically located branches and a well-appointed distributor/dealer network. Structured into Strategic Business Units comprising synergistic groups of responsibility centers (divisions), CG is well on the

INDUCTION
MOTORS

CONTENTS	PAGE NO.
GENERAL	
Standards and Specifications (Indian & International)	1
Manufacturing Summary	2
Frame wise output summary	3
Specifications of Standard products at a glance	4
Special designs offered	5
Mounting arrangements	6
Degree of protection	7
Noise level, Vibration	8
Vibration level severity	9
MECHANICAL FEATURES	
Enclosure	10
Core	10
Winding	10
Insulation	10
Rotor	10
Slip ring & brush gear	10
Shaft	11
Recommended pulley diameter and face width	11
Permissible axial and radial thrusts on shaft	12
Threaded centre holes for motor shaft	13
Bearing reference and lubrication intervals	14-15
Terminal box	16
Terminal box details for standard motors	16
Cable glands	17
Finish	17
ELECTRICAL FEATURES	
Direction of rotation	17
Starting methods and torque	17
Permissible No. of starts per hour	18
Insulation class	18
Earthing	18
Classes of duty	19
Designation/application of duty type	20
Diagrams of duty cycles	21-23
Effect of voltage/frequency variation on motor characteristics	24
Overload	24
Rated speed/slip	24
Locked rotor current	25
Speed torque characteristics	25-26
Locked Rotor withstand time calculation	27-28

CONTENTS	PAGE NO.
General tolerance on electrical performance	28
Accessories	29
Thermistors / Space Heaters	29
Back up fuse selection chart	30
Power factor improvement chart	31
Deration factor chart	32
Thermal withstand time for standard TEFC motors	33
APPLICATIONS	
Air stream rated motors	34
Non-Ventilated motors	34
Multi Speed motors	34
Dual Speed motors	35
Dual Voltage motors	36
Motors For Various Applications	37
TESTING OF MOTORS	
Type Tests	38
Routine Tests/ Other Tests	38
Ordering Information	39
GUIDE AND CHECK POINTS FOR MOTOR SELECTION	
Mechanical Aspects	40
Electrical Aspects	41
DIMENSIONAL DRAWING OF MOTORS	
TEFC SCR MOTORS	
AD 63-132 TEFC Foot Mounted	42
AD 63-132 TEFC Flange Mounted	43
AD 63-132 TEFC Foot cum Flange Mounted	44
AD 63-132 TEFC Face Mounted	45
ND 90S/ND132M TEFC Foot Mounted	46
ND 90S/ND132M TEFC Flange Mounted	47
ND 90S/ND132M TEFC Foot cum Flange Mounted	48
ND 90S/ND132M TEFC Face Mounted	49
ND 160/ND355LX TEFC Foot Mounted	50
ND 160/ND355LX TEFC Flange Mounted	51
ND 160/ND355LX TEFC Foot cum Flange Mounted	52
SPDP SCR MOTORS	
C 160M/C200L SPDP Foot Mounted	53
C 225M/C315MX SPDP Foot Mounted	54
C 160M/C200L SPDP Flange Mounted	55
C 225M/C315MX SPDP Flange Mounted	56

CONTENTS	PAGE NO.
TEFC SR MOTORS	
DW 132S/M TEFC SR Foot Mounted	57
DW 132S/M TEFC SR Flange Mounted	58
NDW 160M/ NDW 355LX TEFC SR Foot Mounted	59
SPDP SR MOTORS	
CW 160M/ CW 200L SPDP SR Foot Mounted	60
CW 225M/ CW 315MX SPDP SR Foot Mounted	61
CONNECTION DIGRAMS	
Connection Diagram for TEFC motors	62
Connection Diagram for TEFC Two Speed motors	63
Connection Diagram for TEFC Multispeed motors	64-65
Connection Diagram for TEFC Dual Voltage motors	65
TERMINAL BOX ARRANGEMENT	
FRAME AD 63/71 (3 Lead)	66
FRAME AD 63/71 (6 Lead)	67
FRAME AD 80	68
FRAME ND90S/ND 132M (3 Leads)	69
FRAME ND 90S/ND 132M (6 Leads)	70
FRAME DW 132S /M	71
FRAME C/ND 160-180, ND200	72
FRAME C 200/250 AND ND 225/280	73
FRAME C/ND 280-315	74
FRAME C315MX,ND315L/355LX	75
PERFORMANCE DATA	
Performance Data of TEFC SCR motors (45/75)	76-78
Performance Data of TEFC SCR motors (50/70)	79
Performance Data of DP SCR motors	79-80
Performance Data of TEFC SR motors	81
Performance Data of DP SR motors	82
SHIPPING SPECIFICATIONS	
TEFC SCR Foot Mounted motors	83
TEFC SCR Flange Mounted motors	84
TEFC SR Foot Mounted motors- TB on Top	85
TEFC SR Foot Mounted motors TB on side	85
TEFC SR Flange Mounted motors	86
DP SCR Foot Mounted motors	86
DP SCR Flange Mounted motors	86
DP SR Foot Mounted motors	87

Standard specifications of Electric Motors

The motors comply with the relevant standard specifications. In particular, they meet the requirement of the following publications:

Indian Standards

- IS 325 : Three phase Induction Motors
- IS 1231 : Dimensions of Three Phase Foot Mounted AC Induction Motors.
- IS-2223 : Dimensions of Flange Mounted AC Induction Motors.
- IS 2253 : Designations for Types of construction and Mounting Arrangements of Rotating Electrical Machines.
- IS 4029 : Guide for Testing Three Phase Induction Motors.
- IS 4691 : Degree of protection provided by Enclosures for Rotating Electrical Machinery
- IS 4722 : Rotating Electrical Machines
- IS 4889 : Methods of Determination of Efficiency of Rotating Electrical Machines
- IS 6362 : Designation of Methods of Cooling for Rotating Electrical Machines
- IS 7538 : Three phase Squirrel cage Induction Motors for Centrifugal pumps for Agricultural Applications
- IS 8151 : Single Speed Three Phase Induction Motors for Driving Lifts.
- IS 8789 : Values of Performance Characteristics for Three Phase Induction Motors.
- IS 12065 : Permissible limits of noise levels for rotating Electrical machines.
- IS 12075 : Mechanical Vibration of Rotating Electrical Machines, Measurement, Evaluation and limits of Vibration Severity.

International standards

- IEC 34 1 : Recommendations for Rotating Electrical Machines.
- IEC 72 1 : Recommendations, Dimensions & output rating of Electrical Machines-Foot Mounting.
- IEC 72 2 : Recommendations for the Dimensions and Output Rating of Electrical Motors-Flange Mounting.

British Standards

- BS 3979 : Dimensions of Electric Motors
- BS 4999 : Specification for general requirements for Rotating Electrical Machines.
- BS 5000 : Specifications for Rotating Electrical Machines.

MANUFACTURING RANGE SUMMARY

OUTPUT	: UP TO 315 kW
TYPE OF ENCLOSURE	: Totally Enclosed Fan Cooled (TEFC)
	Totally Enclosed (TE)
	Drip Proof (DP)
	Flameproof (Type 'd')
	Increased safety (Type 'e')
	Non Sparking (Type 'N')
	Pressurised Type (Type 'p')
TYPE OF ROTOR	: Squirrel cage (SCR)
	Slipring (SR)
MOUNTING	: Foot Mounting (B3,B6,B7,B8,V5,V6)
	Flange Mounting (B5, V1, V3)
	Face Mounting (B14, V18, V19)

TYPE	FRAMES	MOUNTINGS AVAILABLE
TEFC/TE	63 TO 355LX	B3, B5, B6, B7, B8, B34, B35, V1, V3, V5, V6, V36, V18
DP	160 TO 315MX	B3, B5, B35, V1, V3, V15, V36,
TYPE 'd'	80 TO 315L	B3, B5, B35, V1, V3, V15, V36 B14, B34, (ONLY FOR Frame 80 and 160 To180) V18, V19, (ONLY. FOR Frame 80)
TYPE 'e'	90S TO 315L	B3, B5, B6, B7, B8, B14, B35, B34, V1, V3, V15, V36, V18, V19
TYPE 'N'	90S TO 315L	B3, B5, B14, B35, V1, V3, V5, V6, V15, V36
TYPE 'p'	90L TO 315L	B3, B5, B35, V1, V3, V5, V6, V15, V36

VOLTAGE (MEAN)	: 100V TO 650V (STD.415V)
FREQUENCY (MEAN)	: 5Hz TO 75 Hz (STD.50Hz)
DEGREE OF PROTECTION	: UP TO IP56
DUTY	: S1 TO S9
VIBRATION LEVEL	: LOWEST 5 MICRONS
AMBIENT	: -30DEG C TO +65 DEG C
INSULATION CLASS	: CLASS F

FOR ANY OTHER REQUIREMENT, KINDLY REFER TO DIVISION

Table Showing Output Of Standard Continuous rated (S1-Duty) Motors

Frame	Type	Enclosure	Unit	Output			
				2P	4P	6P	8P
AD63/ND355LX	SCR	TEFC	kW	0.18-315	0.18-400	0.37-275	0.37-200
C160/C315MX	SCR	SPDP	kW	9.3-250	9.3-250	7.5-185	3.7-132
NC100/NC132	SCR	DV	kW	2.2-30	2.2-30	1.5-18.5	3.7-15
E80/E315L	SCR	FLP	kW	0.37-200	0.37-200	0.37-160	0.37-132
DW112/NDW355LX	SR	TEFC	kW	-	2.2-250	2.2-160	1.5-132
CW160/CW315MX	SR	SPDP	kW	-	7.5-225	5.5-160	3.7-132
EW250/EW315L	SR	FLP	kW	-	26-160	18.5-132	15-100

SPECIFICATIONS OF STANDARD PRODUCTS AT A GLANCE

MOTOR TYPE	TEFC-SCR	TEFC-SR	DP-SCR	DP-SR
VOLTAGE VARIATION	415 +/-10%			
FREQUENCY VARIATION	50HZ +/-5%			
COMBINED VARIATION	10% (ABSOLUTE SUM)			
FRAME DIMENSIONS	AS per IS 1231			
CLASS OF INSULATION	"F"			
AMBIENT TEMPRATURE/ TEMP. RISE (BY RESISTANCE)	AS PER RELEVANT PERFORMANCE FIGURES			
ALTITUDE	MAXIMUM OF 1000 METER			
RELATIVE HUMIDITY	UP TO 100 %		UP TO 50 %	
ATMOSPHERIC CONDITION	Non corrosive and non hazardous Atmosphere			
RATING/DUTY	Continuous/S1			
DEGREE OF PROTECTION	IP 55 (As per IS 4691)		IP 21 For Frames from 160 and above IP 23 For Frame 100-132	
MOUNTING REFERENCE	As per IS 2253			
MECHANICAL DIMENSION	As per Relevant Dimensional Drawings			
POSITION OF TERMINAL BOX	RHS viewing From Driving End For D80-ND355L and AD63-AD100L	On Top for For NDW160M TO NDW355LX	RHS viewing From Driving End For C160 to C315MX	RHS viewing From Driving End For CW160 to CW315MX
ARRANGEMENT OF TERMINALS	As per relevant Terminal box arrangement drawings			
CONNECTION	Upto 1.5 KW & 2.2 KW 4-P-STAR 2.2 KW 2/6/8 & above - DELTA	Stator: DELTA Rotor: STAR/DELTA	Upto 1.5 KW & 2.2 KW 4-P-STAR 2.2 KW 2/6/8 & above - DELTA	Stator: DELTA Rotor: STAR
NO. OF LEADS	Upto 1.5 KW & 2.2 KW 2/4-P-3 2.2 KW 6-8 P & above -6	3 LEADS/3 LEADS	Upto 1.5 KW & 2.2 KW 2/4-P-3 2.2 KW 6-8 P & above -6	3 LEADS/3 LEADS
DIRECTION OF ROTATION	Bi-directional		Bi-directional Except 280,315-2 pole ACW from DE	Bi-directional
GREASE Type Greasing Arrangement	Lithium Soap Base Grade II - Online Greasing arrangement for 250 and above - Grease valve assembly for frame 250 and above on both sides - Sealed for life bearings Upto 225 frame			
BEARING SEAL	V- Seal with cap for Frame 160 and above Oil Seal for Frames 63 to 132 M		-	
VIBRATION LEVEL	As per Normal Class of IS12075			
NOISE LEVEL	As per IS12065			
OVERLOAD CAPACITY	Capable of withstanding 60% Overload for 15 sec.			
OVERSPEED	120% over speed for 2 minutes			
PAINT	Synthetic Enamel (Light grey shade 631 as per IS:5)			
POSITION OF SLIPRING	On Top Frame 160 and Above			
INSPECTION WINDOW	On Side Frame 132S /132M			

SPECIAL DESIGNS OFFERED

ELECTRICAL	MECHANICAL
Non Standard Voltage And Frequency Variation	Non Standard Mounting Dimensions
Duel Voltage (1:2 or 1:√3 Ratio) Triple Voltage (1:√3 : 2 Ratio)	Special shaft Extension
Inverter fed Supplies And AC Variable Speed drives	Double shaft Extension
Multispeed Motors Upto 4 different speeds Motors	Separately Ventilated
Energy Efficient Motors	Low Vibration & Noise Level
High Slip Motors	Shock Grade Motors
Motors For frequent starts/stops/reversals (e.g. crane duty)	Motors for Hazardous areas
Torque Motors	Motors For Dust Laden Atmosphere
High Frequency Motors	Brake Motors
Textiles Motors	Geared Motors
10,12,16,18,24,32 Pole Motors	Special Bearings like Thrust Bearings
Special Performance Requirements	Tacho Mounting
Class H insulated Motors	Non Standard Paint Shade and Painting Procedure for required Dry Film Thickness
Motors With Service Factor	Fabricated Steel Enclosure Alternate Terminal Box Position
Slipring Motors with Bar-wound rotors for Frames 280 to 355	Special Shaft Material
	Stainless Steel/ Brass Hardware Accessories like Resistance Temperature Detectors, Bearing Temperature Detectors, Thermocouples, Plug & Socket
	Custom Size Fabricated terminal box & Terminal Arrangements.
	Canopy

MOUNTING ARRANGMENTS

HORIZONTAL		
FIGURE		
REF	B3	B5
FRAME	WITH FEET	WITHOUT FEET
SHAFT	HORIZONTAL	HORIZONTAL
MTNG	BASE OR RAILS	FLANGE TYPE D
FIGURE		
REF	B35	B14
FRAME	WITH FEET & FLANGE	WITHOUT FEET
SHAFT	HORIZONTAL	HORIZONTAL
MTNG	BASE OR FLANGE TYPE D	FLANGE TYPE C
FIGURE		
REF	B34	B6
FRAME	WITH FEET	WITH FEET
SHAFT	HORIZONTAL	HORIZONTAL
MTNG	BASE OR FLANGE TYPE C	WALL
FIGURE		
REF	B7	B8
FRAME	WITH FEET	WITH FEET
SHAFT	HORIZONTAL	HORIZONTAL
MTNG	WALL	CEILING

* For installation of foot mounted motor on the wall, additional support must be provided.

VERTICAL		
FIGURE		
REF	V1	V5
FRAME	WITHOUT FEET	WITH FEET
SHAFT	FACE VERT. DOWN	FACE VERT. DOWN
MTNG	FLANGE TYPE D	BASE OR RAILS
FIGURE		
REF	V15	V3
FRAME	WITH FEET	WITHOUT FEET
SHAFT	FACE VERT. DOWN	FACE VERT. UP
MTNG	WALL OR FLANGE TYPE D	FLANGE TYPE D
FIGURE		
REF	V36	V6
FRAME	WITH FEET	WITH FEET
SHAFT	FACE VERT. UP	FACE VERT. UP
MTNG	WALL OR FLANGE TYPE D	BASE OR RAILS
FIGURE		
REF	V18	V19
FRAME	WITHOUT FEET	WITHOUT FEET
SHAFT	FACE VERT. DOWN	FACE VERT. UP
MTNG	FLANGE TYPE C	FLANGE TYPE C

REFERENCE : IS 2253

DEGREE OF PROTECTION

The degree of protection as classified in IS:4691 is given below. It is denoted by two digits. The first digit denotes protection against solid bodies or particles and the second digit denotes protection against liquid. All our standard TEFC motors have degree of protection IP 55, unless otherwise specified.

Second Characteristic Numeral							
First Characteristic Numeral	No Protection	Water falling Vertically shall not harm	Water falling up to 15° from vertical shall not harm	Water falling upto 60° from vertical shall not harm	Water splashes shall not harm	Water projected by nozzle shall not harm	Water from heavy seas shall not harm
	0	1	2	3	4	5	6
0	No Protection						
1	Special Protection against bodies 50 mm dia.						
2	DP protection against bodies 12 mm dia	IP 21	IP 22	IP 23			
4	TEFC Protection against bodies 1 mm dia				IP 44		
5	TEFC Protection against powder				IP 54	IP 55	IP 56

NOISE LEVEL

The noise level of the motors is restricted to the levels specified in IS : 12065. Table below gives the noise level as per IS : 12065

Limiting Mean Sound Power Level L_w in dB (A) for Airborne noise emitted by Rotating Electrical Machines.

Protective Enclosure	IP 21	IP 44	IP 21	IP 44	IP 21	IP 44	IP 21	IP 44	IP 21	IP 44	IP 21	IP 44	
Rating kW (or kVA)	Rated Speed (rev./min.)												
	960 & below		961 to 1320		1321 to 1900		1901 to 2360		2361 to 3150		3151 to 3750		
Above	Upto	Sound Power Level dB (A)											
-	1.1	-	76	-	79	-	80	-	83	-	84	-	88
1.1	2.2	-	79	-	80	-	83	-	87	-	89	-	91
2.2	5.5	-	82	-	84	-	87	-	92	-	93	-	95
5.5	11	82	85	85	88	88	91	91	96	94	97	97	100
11	22	86	89	89	93	92	96	94	98	97	101	100	103
22	37	89	91	92	95	94	97	96	100	99	103	102	105
37	55	90	92	94	97	97	99	99	103	101	105	104	107
55	110	94	96	97	101	100	104	102	105	104	107	106	109
110	220	98	100	100	104	103	106	105	108	107	110	108	112
220	630	100	102	104	106	106	109	107	111	108	112	110	114

Note 1: IP 21 corresponds generally to drip proof open ventilated & similar enclosures.
IP 44 corresponds generally to totally enclosed fan-cooled, closed air circuit air-cooled & similar enclosure (see IS-4691)

VIBRATION.

The motor is said to be in state of vibration if any part of it experiences displacement in any direction. Standard motors comply with normal class of vibration severity as per IS 12075. "Measurement & evaluation of vibration of Rotating Electrical Machines". The limits of vibration levels are given below.

VIBRATION LEVELS

LIMITS OF VIBRATION SEVERITY IN ROTATING ELECTRICAL MACHINES MEASURED IN STATE OF FREE SUSPENSION *

Shaft height H, mm	56 to 132		160 to 225		Above 225	
Range of speed (Rpm)	600 to 1500	Above 1500 & Upto 3000	600 to 1500	Above 1500 & Upto 3000	600 to 1500	Above 1500 & Upto 3000
Class of vibration Severity	RMS Value of Vibration Velocity, mm/s					
Normal	1.8	1.8	1.8	2.8	2.8	4.5
Precision A	0.71	0.71	0.71	1.12	-	-
Precision B	0.45	0.45	0.45	0.71	-	-
Precision C	0.28	0.28	0.28	0.45	-	-

* The vibration may be determined in rigid mounting condition but the value of vibration severity shall be agreed by a special agreement between the manufacturer & the user.

DERIVED VALUES OF VIBRATION SEVERITY IN ROTATING ELECTRICAL MACHINE MEASURED IN STATE OF FREE SUSPENSION*

SHAFT HEIGHT H, mm	56 TO 132				160 TO 225					Above 225				
	Pole	8	6	4	2	10	8	6	4	2	10	8	6	4
Syn. Speed, rpm.	750	1000	1500	3000	600	750	1000	1500	3000	600	750	1000	1500	3000
Class of vibration severity	RMS Value of Vibration Velocity, microns													
Normal	64	48	32	16	80	64	48	32	25	125	100	75	50	42
Precision A	24	18	12	6	30	24	18	12	10	-	-	-	-	-
Precision B	16	12	8	4	20	16	12	8	6	-	-	-	-	-
Precision C	10	8	5	2.5	13	10	8	5	4	-	-	-	-	-

*The vibration may be determined in rigid mounting condition but the values of vibration severity shall be agreed between the manufacturer and the user.

MECHANICAL FEATURES

GENERAL

ENCLOSURE

Frames 63 to 100 L with prefixes AD are of diecast aluminum. Foot mounted stators have integral feet. TEFC & TE motors have integral longitudinal ribs for effective heat transfer. Specially designed roller table motors for steel plants have circular ribs to avoid deposition of dust & slags between the ribs.

The stator & end shields are machined to close tolerances for providing perfect alignment & fits.

Terminal boxes of frames up to 132M are of diecast aluminum alloy. Frame 160 & above have cast iron terminal box. All joints in terminal box are sealed with gaskets.

Motors above frame 160 have drain holes at their lowest position as a standard features.

CORE

Both stator and rotor cores are made of high quality magnetic steel

WINDINGS

Stator and rotor (for SR motors) windings consists of modified polyester enamel covered copper wire. Frame 280 and above are wound with dual coat copper wire as per IS: 13730-13. Motors wound with double glass covered conductors are also available on order for frame 160 and above only.

INSULATION

All motors are made with class F insulation as a standard feature.

The slot liners are either provided with double cuffing or edge binding at the slot mouth portion to strengthen the insulation. For frame 160 & above class F varnish or resin with vacuum pressure impregnation is used for impregnating the winding.

Epoxy gel coat is sprayed on all winding overhangs (in frames 200 and above) to provide mechanical rigidity to the winding to withstand the electrical and mechanical stresses.

Surge testing is carried out on all windings in addition to all other tests ensuring healthiness of windings.

The overhangs of SR rotors are banded with resi-glass tape under controlled tension, to prevent flaring under centrifugal force caused by over speed.

ROTOR

The rotor of SCR motors are made of pressure diecast aluminum (or alloy in case of special designs) up to frame ND355L. Rotors of specific polarity are made of electrolytic copper & copper alloy bars & rings connected by high quality silver brazing.

The rotors of SR (slipring) motors are wound with copper wire or strip. (See in winding and insulation)

SLIPRING AND BRUSHGEAR

SR motors are provided with slipring and brush gear arrangement. The Sliprings are moulded in epoxy-based insulation and have excellent stability at high temperature and have very good anti tracking property. Fabricated Sliprings as per Steel Plant's specification (IPSS) are also available on request for frames 160 & above.

3 Nos. brush holders with 2 nos each metal graphite carbon brushes are provided- one on each ring phase. The grade of carbon brush is M15E of Assam carbon or equivalent. Each carbon brush is marked with its grade and the line of wear, which helps in identifying replacement need.

The brush holders are made of brass. For 160 to 200, self tension adjustment brush holders are used. Frames 225 and above have adjustable arms to suit the range of slipring diameter. This always facilitates angular adjustment of arms for radial placement of brushes even after reduction in diameter of slipring, resulting out of any rework carried out in service. The brush tension is adjustable with the help of adjustable nuts provided on the brush arm. The sizes of brush and recommended force for all frames are as given in the table:

FRAME	BRUSH SIZE = t x a	RECOMMENDED FORCE/BRUSH
112-132	8 x 12.5 sq.mm	200gms. - 250gms.
160-200	16 x 24 sq.mm	200gms. - 250gms.
225-250	16 x 20 sq. mm	650gms. - 800gms.
280-315	20 x 40 sq. mm	1600gms. - 2000gms.

SHAFT

The shaft is made of C40 (EN8) steel. Shaft bars above 50mm diameter are ultrasonically tested for detection of flaws, before taken up for machining. Shaft made of special steel (i.e.EN24, EN57 or stainless steel grades) are also available on demand to suit the requirement of application.

MAXIMUM PERMISSIBLE RADIAL PULL KG. AT THE CENTRE OF SHAFT EXTENSION (INCLUDING PULLEY WEIGHT)

SYNC. RPM	3000	1500	1000	750
FRAME				
63	42	46	-	-
71	46	55	-	-
80	53	66	76	-
90	46	57	66	72
100	66	83	96	106
112	95	120	138	153
132	137	173	198	218
160	255	305	305	305
180	300	380	395	395
200	400	505	580	580
225	450	570	655	655
250	510	1095	1095	1095
280	510	1790	1790	1790
315	560	1905	1905	1905
355	590	2000	2000	2100

MINIMUM DIAMETER AND MAXIMUM FACE WIDTH OF PULLEY IN mm

SYNC. RPM	3000	1500 and BELOW	
FRAME	PULLEY DIA		FACE WIDTH
63	75	75	30
71	75	75	40
80	75	75	50
90	75	75	63
100	75	75	80
112	100	100	100
132	120	120	125
160	120	180	177
180	125	200	203
200	130	220	280
225	170	260	330
250	180	220	380
280	300	220	380
315	500	420	380
355	600	450	400

MAXIMUM PERMISSIBLE AXIAL THRUST IN KG. CONSIDERING EXTERNAL RADIAL THRUST TO BE ABSENT

SYNC. RPM	3000		1500		1000		750	
	HORIZONTAL	VERTICAL DOWNWARDS	HORIZONTAL	VERTICAL DOWNWARDS	HORIZONTAL	VERTICAL DOWNWARDS	HORIZONTAL	VERTICAL DOWNWARDS
63	18	24	30	40	-	-	-	-
71	21	28	36	48	-	-	-	-
80	35	33	43	40	50	48	-	-
90	30	27	38	33	43	38	48	43
100	42	37	53	47	60	54	67	61
112	60	53	75	67	87	79	96	88
132	88	75	110	94	127	109	140	122
160	170	140	225	208	265	245	300	280
180	195	160	260	230	310	280	345	320
200	260	210	340	270	410	360	480	420
225	285	230	380	325	455	380	515	440
250	325	250	470	290	555	390	360	480
280	325	220	580	350	680	440	765	520
315	355	280	610	320	730	430	810	540
355	385	310	640	390	760	460	850	580

NOTE: For radial or Axial thrust exceeding the values given in above table, please refer to works.

BEARING LIFE: The minimum L_{10} life of bearings for standard motors is 40000 hours subject to operations under conditions of maximum permissible radial thrust, axial thrust and minimum diameter and maximum face width of pulley.

THREADED CENTERED HOLES FOR MOTOR SHAFT

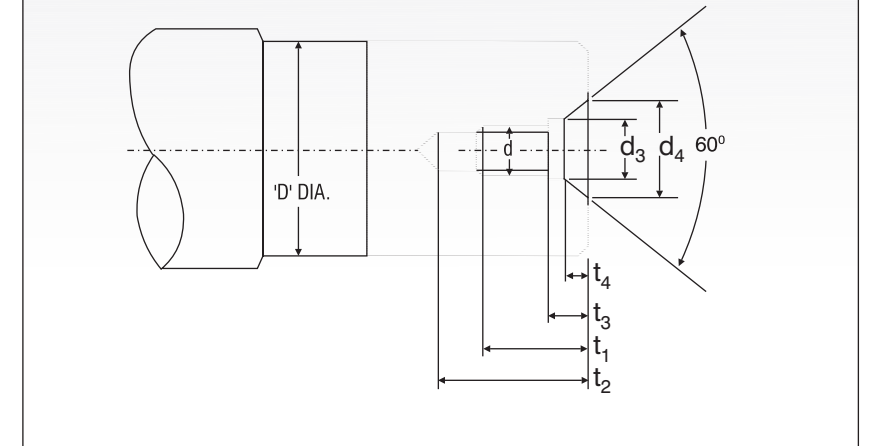

Diameter Range 'D'	Thread d	d3	d4	t_{1-0}^{+2}	t_2 (min)	t_3	t_4
7 to 10	M3	3.2	5.3	9	13	2.6	1.8
10 to 13	M4	4.3	6.7	10	14	3.2	2.1
13 to 16	M5	5.3	8.1	12.5	17	4	2.4
16 to 21	M6	6.4	9.6	16	21	5	2.8
21 to 24	M8	8.4	12.2	19	25	6	3.3
24 to 30	M10	10.5	14.9	22	30	7.5	3.8
30 to 38	M12	13	18.1	28	37.5	9.5	4.4
38 to 50	M16	17	23	36	45	12	5.2
50 to 85	M20	21	28.4	42	53	15	6.4
85 to 130	M24	25	34.2	50	63	18	8

Dimensions are as per DIN 332 part 2 and are in mm.

BEARING REFERENCE AND LUBRICATION INTERVALS

BEARING AND LUBRICATION : Motors above frame 250 are provided with deep groove ball Bearings with on line greasing arrangement. Motors upto frame 225 are provided with sealed ball bearings. A guideline for relubrication is available in the chart given below.

GREASE : Lithium Base Grease grade II
GREASE QUANTITY Complete space between rolling elements of bearings and half of the Space inside and outside of bearing cover to be filled by grease.

GREASE EXPIRY DATE : Ensure that grease is used before the expiry date as stated by the Manufacturer.
RELUBRICATION CHART (IN HOURS)

FRAME SIZE	DE BRG	NDE BRG	Interval For Relubrication In Hours For Respective Syn. Speed				
			2 POLE	4 POLE	6 POLE	8 POLE	10/12POLE
AD63	6201ZZ	6201ZZ	--	--	--	--	--
AD71	6203ZZ	6203ZZ	--	--	--	--	--
AD/D80	6204ZZ	6204ZZ	--	--	--	--	--
ND/D90S/L	6205ZZ	6205ZZ	--	--	--	--	--
ND/NC100L/LX	6206ZZ	6205ZZ	--	--	--	--	--
ND112M@	6306ZZ	6205ZZ	--	--	--	--	--
ND112MX/NC112M	6206ZZ	6205ZZ	--	--	--	--	--
ND 132 S/M	6308ZZ	6208ZZ	--	--	--	--	--
DW132S/M(SR)*	6208ZZ	6307ZZ	--	--	--	--	--
ND160M/L	6309 2RS	6309 2RS	--	--	--	--	--
ND180M/L	6310 2RS	6310 2RS	--	--	--	--	--
ND200L	6312 2RS	6312 2RS	--	--	--	--	--
ND225S/M	6313 2RS	6313 2RS	--	--	--	--	--
ND250 S/M 2POLE	6314	6314	2500	--	--	--	--
ND250M S/M 4P & UP	6314	6314	--	3500	5000	7750	10500
ND280S/M 2P POLE	6314	6314	2500	--	--	--	--
ND280S/M 4P & UP	6318	6318	--	2900	4750	7250	9500
ND315S/M/L-2 POLE	6315	6315	2300	--	--	--	--
ND315S/M/L 4P & UP	6319	6319	--	2500	4500	7000	9000
ND355 S/M/L 2P	6315	6315	2300	--	--	--	--
ND355S/M/L 4P & UP	6321	6321	--	2500	4500	7000	9000
ND355LX 4P & UP	6322	6322	1000	2500	4500	7000	9000
C160M/L	6310 2RS	6310 2RS	--	--	--	--	--
C180M/L	6312 2RS	6312 2RS	--	--	--	--	--
C200M/L	6313 2RS	6313 2RS	--	--	--	--	--
C225S/M	6314	6314	2500	7800	12800	18000	23000
C250S/M-2 POLE	6314	6314	2500	--	--	--	--
C250S/M-4P & UP	NU316	6316	--	3500	5000	7750	10500
C280S/M-2 POLE	6314	6314	2500	--	--	--	--
C280S/M/MX-4P & UP	NU318	6318	--	2900	4750	7250	9500
C315S/M/MX-2 POLE	6315	6315	2300	--	--	--	--
C315S/M/MX-4P & UP	NU319	6319	--	2500	4500	7000	9000

Bearings are common for CAST IRON and ALUMINIUM body motors upto frame size 100L/LX.

* For single shaft extension. For double shaft extension-Bearing Size- 6208/6208.

Bearings are common for SR and SCR 4 pole up wherever not mentioned.

Bearing clearance-

Motors upto 132M have normal clearance bearings.

Motors in Frame 160 & above have C3 clearance Bearings.

@ For single shaft extension only.

TERMINAL BOX

Terminal boxes of all motors are rotatable in steps of 90° except aluminum body motor in 80 frame. This feature has been incorporated in order to facilitate cable entry from any direction. However, terminal boxes which are fitted with trifurcating box (frame 225 & above) would need sufficient space underneath, for cable entry from bottom, as the trifurcating box ends below the level of motor feet. For cast iron body motors (Frame 80 132 M), sufficient space is to be provided below the terminal box where cable entry is to be provided from bottom.

The terminal box provided for standard motors is of die cast aluminum alloy or of cast iron. The degree of protection provided is IP55. The detailed dimensions of terminal box are given in the drawings included in the catalogue. As a standard practice, for cast iron body motors, the terminal box is provided on the right hand side, when viewed from driving end. When required, terminal box can be provided on left hand side when viewed from driving end.

For aluminum Frames (AD63 to AD100L), terminal box is on top. For ND 132 to ND 355 frames, terminal box can also be provided on top, on request.

For motors rated upto and including 2.2.kW (3HP) 2pole/4pole are provided with 3 terminals. For 2.2.kW (3HP) 6pole/8pole and 3 kW and above are provided with 6 terminals as a standard practice. The terminal markings U, V, W or U1, V1, W1, & U2, V2, W2 are provided on the motor lead sockets.

Standard motors in frame 160 & above are provided with double decker terminal block for easy termination of two cables for Star/Delta starting.

Cable trifurcating box is provided in Frames 225 & above.

Antirotating socket arrangement is a standard feature in frame 225 & above.

Clearance & creepage distances in the terminal box for Frames 63 to 132 M are as per BS : 4999 part 145. For frames 160 & above, distances are as per IS: 6381.

TEFC FRAME	DP FRAME	MAXIMUM CABLE SIZE		NO. OF MAIN TERMINALS	TERMINAL STUD SIZE		BSC ENTRY	
		DOL	STAR/DELTA		MAIN	EARTH	NOS.	SIZE
AD63-AD71	-	4Cx4mm ²	-	3	M5	M4	1	¾"
AD80 *	-	4Cx4mm ²	-	3	M5	M4	2	¾"
D80	-	4Cx4mm ²	-	3	M5	M4	1	¾"
D90S/L	-	4Cx10mm ²	-	3	M6	M5	1	¾"
ND90S-ND132M	-	4Cx10mm ²	4Cx10mm ²	# 6	M6	M5	DOL-1, S/D-2	1"
AD90S-AD100L	-	4Cx10mm ²	-	3	M6	M5	1	1"
NC100L-NC132M	-	4Cx10mm ²	4Cx10mm ²	6	M6	M5	DOL-1, S/D-2	1"
ND160-ND200	C160&C180	3Cx50mm ²	2x3Cx35mm ²	6	M6	M8	2	1"
ND225-ND280	C200 - C250	3Cx120mm ²	2X3C X95mm ²	6	M8	M12 for ND250 & ND280 M8 for others	2	1 ½"
ND315S/M/L	C280- C315S/M/MX	3Cx400mm ²	2x3Cx300 mm ²	6	M12	M12	2	2"
ND355L/LX	---	3Cx400 mm ²	2x3Cx300 mm ²	6	M16	M12	2	2.5"

* INTEGRAL TERMINAL BOX

3 Leads upto 2.2 kW 2 P/4P & 1.5 Kw 6P/8P and below
6 leads for 2.2 kW 6p/8p & above

CABLE GLANDS

Standard TEFC & DP motors are provided with threaded cable entry. These holes are plugged with PVC plugs. On request, double compression type cable glands (made of nickel plated brass) can be fitted on terminal box. The type of cable & its size in that case is required to be mentioned at the order stage itself.

FINISH:

All castings and M .S. components are provided with red oxide primer and aluminum components with zinc chromate primer. The motors are finally painted with synthetic enamel paint of shade-Light gray 631 as per IS : 5

For the motors required to operate in acidic and alkaline or any other corrosive atmosphere, the motor components are suitably treated to withstand corrosion due to such atmosphere and are then painted with Epoxy Base paint of colour Light Grey shade 631 as per IS 5. Any other shade can be given on request.

ELECTRICAL FEATURES

Direction of Rotation

Motors are capable of rotating in either direction except in 280/315 SPDP Frame 2 pole motors. To reverse the direction of rotation, interchanges any of two-phase connection. For 2 pole motors in 280/315SPDP frame the direction of rotation

is to be specified at the time of ordering. Motors may be provided with arrow plate to indicate direction of rotation.

Starting Methods And Torque

DOL Starting: Direct connection to the mains is the simplest method of starting for squirrel cage motors. Normally, motors Upto 2.2 Kw are started DOL, However all our motors are capable of starting on DOL.

Star-Delta Starting The current impulse caused during the DOL starting of motors of higher ratings, lead to the drop in the voltage of the system. In such cases the motors are generally started by means of star-delta starters, wherein the motor terminals get connected in star at the time of starting thereby reducing the starting current. When the motor is accelerated to nearly 70 % of full speed, the connections at the motor terminals are changed to delta, for the normal running of the motor on load SR Motors are started with SR starters having resistance banks matching with rotor current of the motor. Star connected motor can have only DOL starting.

Operating data for the motors being run by star-delta starters.

Operating Data	Starting on star	Running on Delta
Supply Voltage	415	415
Voltage across each phase of winding	230	415
Current in supply cable	1/√3	1
Current in phase winding	1/√3	1/√3
Breakaway Torque (starting Torque)	1/3 of STT. When started on DOL	-----
Locked rotor current (starting current)	1/3 Isc when started on DOL	

Permissible No of starts: 2 hot or 3 cold in succession or 4 equally spaced starts.

The number of starts takes into account: -Complete starts, inching & plug reversal on the following basis.

One inching (an incomplete start in which motor speed do not cross 25% of rated speed)	Equivalent to 1/4 th start.
In case of SR motors: One plug braking (Reversal of any two phases till motor reaches standstill)	Equivalent to 80% of one start
In case of SR motors: One plug reversal two (reversal of any phases, till motor picks up full speed in reverse direction)	Equivalent to 1.8 starts.
In case of SCR motors One plug braking	Equivalent to 3 starts.
One DC injection braking	Equivalent to 2 starts.
One plug reversal	Equivalent to 4 starts.

Motors required with higher starting i.e. (6,90,150,300,600 starts /hr) are suitable for intermittent periodic duties

INSULATION CLASS

Standard Motors are provided with windings having class “F” Insulation with maximum permissible temperature rise limited to class “B” insulation level. On request , motors are provided with Class “H” insulation.

Table showing maximum temperature rise at various ambient and the * Hot spot temperature for the insulation system is given below:

Class of Insulation	Max. Permissible Temp. Limit (°C)	* Hot Spot Allowance (°C)	Max. Permissible Temperature Rise for windings at Ambient of (°C)				
			40	45	50	55	60
B	130	10	80	75	70	65	60
F	155	15	100	95	90	85	80
H	180	15	125	120	115	110	105

*Hot spot Allowance is an empirical value expressed in °C, by which the hottest spot of winding can exceed the mean temperature rise of the winding.

EARTHING

Earthing pads are provided on the stator for all frames. One no. M5 screw is provided on either side for 63-80 frame Aluminum body motors. Two numbers of M6 screws and washers are provided for earthing on motor from frame 80 to 132, whereas M8 screws and washers are provided for earthing in frame 160 to 225. For Frames 250,280,315&355 Frames M12 screws are provided.

Additional earthing is provided inside the terminal box (see terminal box details)

DUTY

The various operating cycles of driven machines can be classified into nine basic duties, ranging from S1 to S9 separately indicated in the following pages. Suitable motors can be offered to match the duty cycles of the driven machines.

CLASSES OF DUTY

The following are the duty types:

- S1 Continuous running duty
- S2 Short time duty
- S3 Intermittent periodic duty
- S4 Intermittent periodic duty with starting
- S5 Intermittent periodic duty with Electric braking
- S6 Continuous operation periodic duty
- S7 Continuous operation periodic duty with Electric braking
- S8 Continuous operation periodic duty with related load/ speed changes
- S9 Duty with Non-periodic load & speed variations.

Continuous running duty (Duty type S1)

Operation at constant load of sufficient duration till thermal equilibrium is reached.

Short Time Duty (Duty type S2)

Operation at constant load during a given time, less than that required to reach thermal equilibrium, followed by a rest of sufficient duration to re-establish equality of temperature with the cooling medium. The recommended values for the short time duty are 10,30,60 and 90 minutes.

Intermittent Periodic Duty (Duty type S3)

A sequence of identical duty cycles, each consisting of a period of operation at constant load and a rest period, these periods being too short to attain thermal equilibrium during one duty cycle. In this duty type, the starting current does not significantly affect the temperature-rise. Unless otherwise specified, the duration of the duty cycle is 10 minutes. The recommended values for the load factor are 15,25,40 and 60 percent.

Intermittent Periodic Duty with Starting (Duty type S4)

A sequence of identical duty cycles, each consisting of a period of starting, a period of operation at constant load and a rest period,

the operating and rest and de-energized being too short to attain thermal equilibrium during one duty cycle. In this duty the stopping of the motor is obtained either by natural deceleration after disconnection of the electricity supply or by means of braking such a mechanical brake which does not cause additional heating of the windings

Intermittent periodic duty with Electric braking (Duty type S5)

A sequence of identical duty cycles, each consisting of a period of starting, a period of operation at constant load, a period of braking and a rest period. The operating and de-energized periods being too short to obtain thermal equilibrium during one duty cycle

In this duty braking is rapid and is carried out electrically.

Continuous operation periodic duty (Duty type S6)

A sequence of identical duty cycles, each consisting of a period of operation at constant load and a period of operation at no-load, machines with excited windings having normal no load rated voltage excitation. The operation and no-load periods are too short to attain thermal equilibrium during one duty cycle

Unless otherwise specified the duration of the duty cycle is 10 minutes.

Continuous operation periodic duty with Electric braking (Duty type S7)

A sequence of identical duty cycles each consisting of a period of starting, a period of operation at constant load and a period of electrical braking. There is no rest and de-energized period.

Continuous operation periodic duty with related load/ speed changes (Duty Type S8)

A sequence of identical duty cycles each consists of a period of operation at constant load corresponding to a determined speed of rotation, followed immediately by a period of operation of another load corresponding to a different speed of rotation (carried out, for example by means of change of the number of poles in the case of induction motors), the operating periods being too short to attain equilibrium during one duty cycle. There is no rest and de energized period.

APPLICATION OF THE DUTY TYPE, RATED MOTORS

DUTY	APPLICATION
S1	Pumps, blowers, Fans, Compressors
S2	Operation of gates of dams, sirens, Capstan.
S3	Valve actuators, Wire drawing machine
S4	Hoists, Cranes, Lifts
S5	Hoists, Cranes, Rolling Mills
S6	Conveyors, Machine Tools
S7	Machine Tools
S8, S9	Special application where the motor is required to run at different speeds and different loads.

S2/S3 DUTY RATED MOTOR OUTPUTS

Standard motors can be used for S2 and S3 duties with increased outputs, however, the starting torque and pull out torque as percentage of full load torque would be reduced. The ratings indicated in the table are with minimum 200% pull out torque.

DIAGRAMS OF DUTY CYCLES

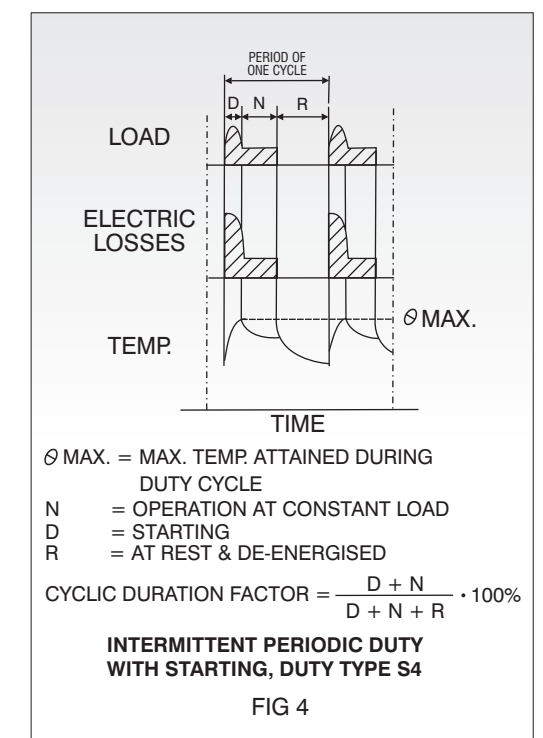
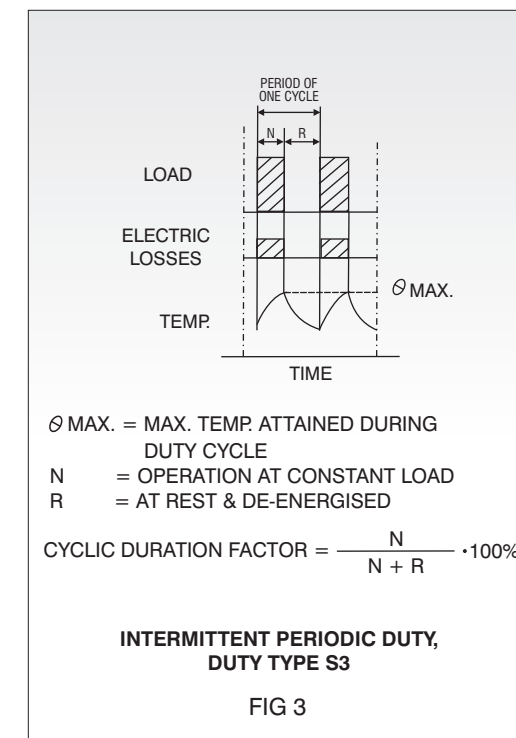
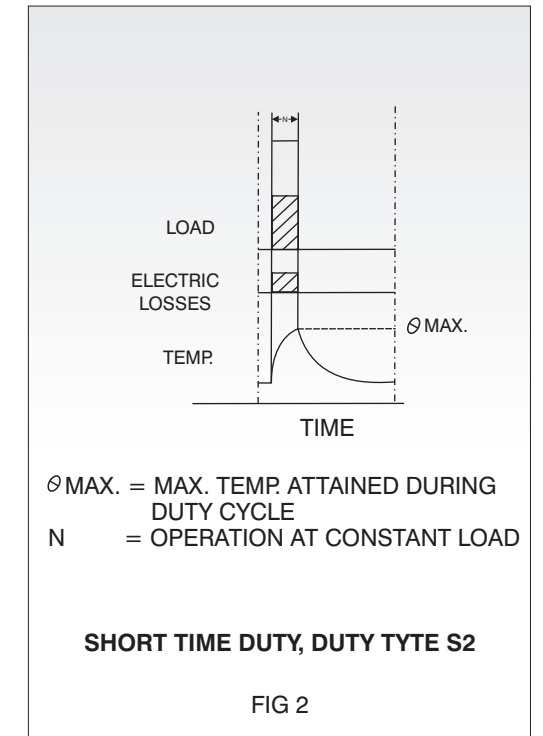
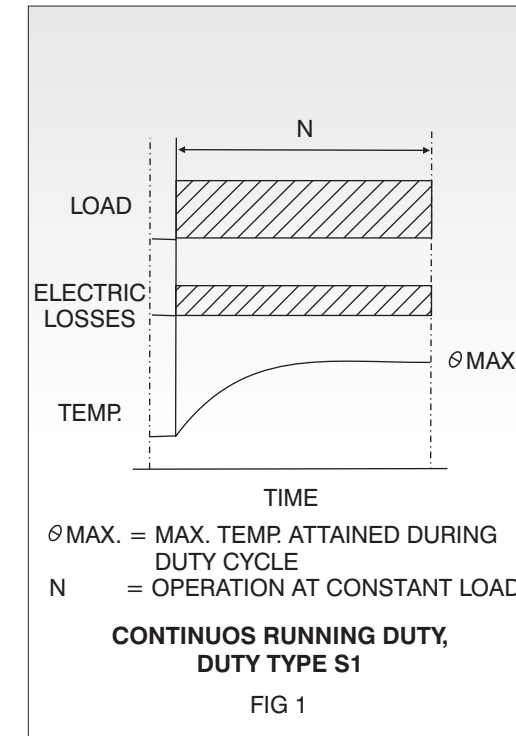

DIAGRAMS OF DUTY CYCLE

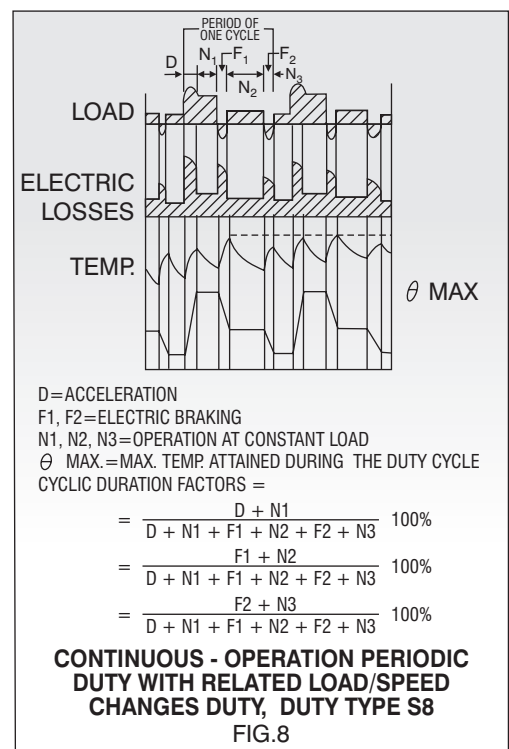
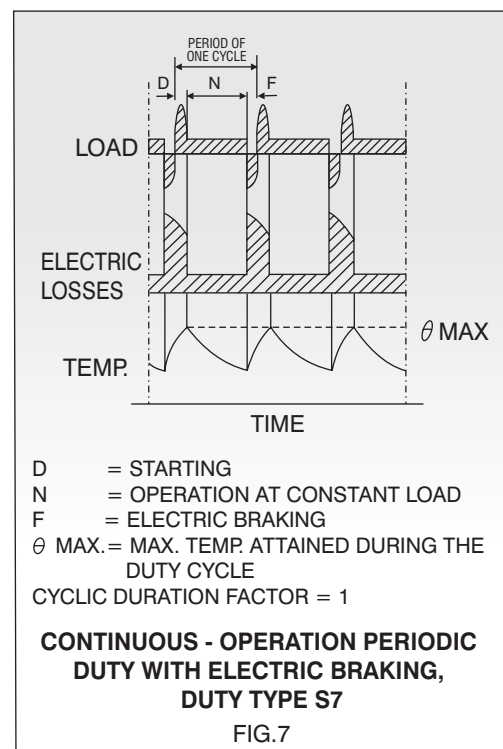
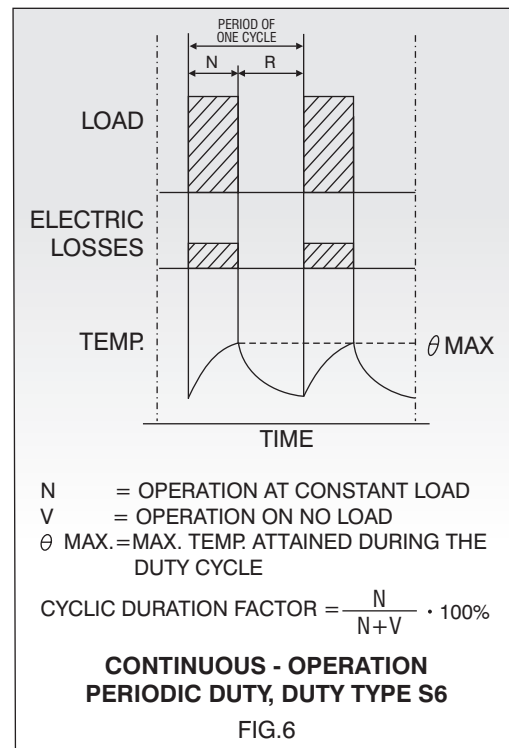
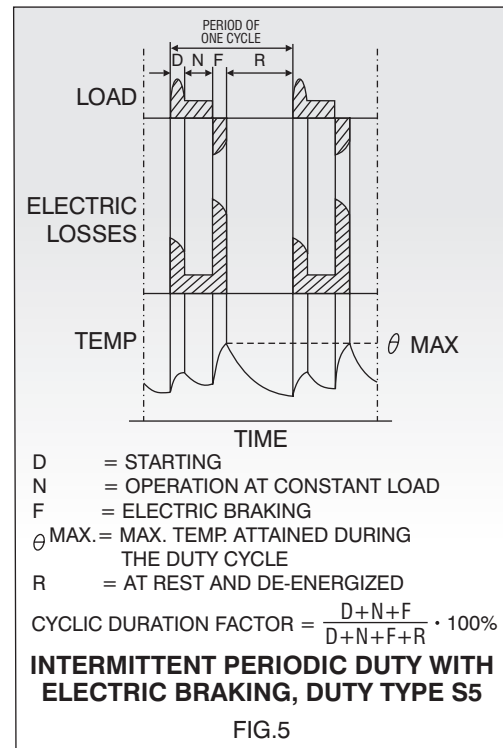

DIAGRAMS OF DUTY CYCLES

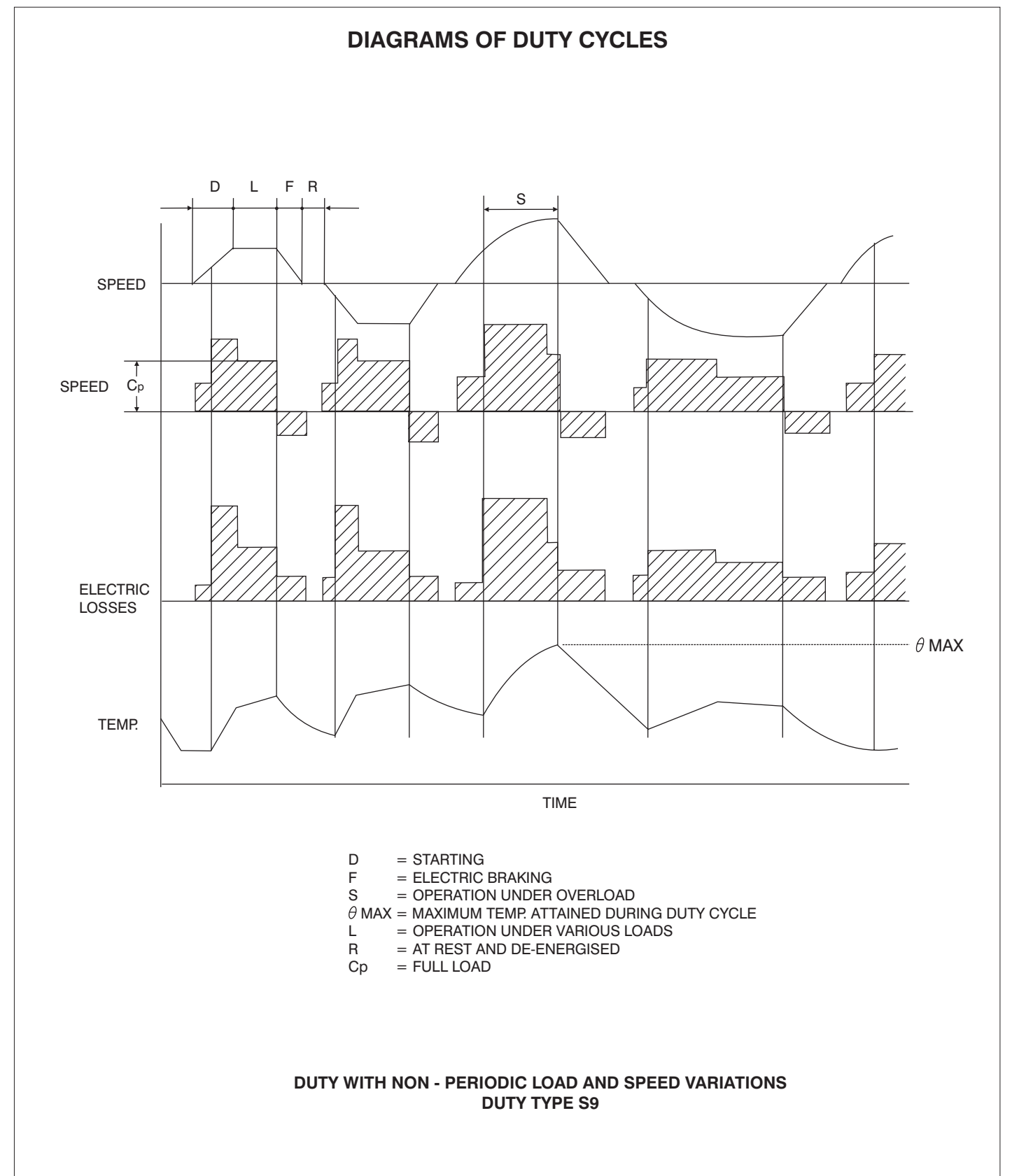

EFFECT OF VARIATION OF VOLTAGE AND FREQUENCY ON THE CHARACTERISTICS OF MOTOR

Characteristics	Voltage		Frequency	
	110%	90%	105%	95%
Torque Starting & Maximum	Increase 21%	Decrease 19%	Decrease 10%	Increase 11%
Speed Synchronous Full Load	No Change Increase 1%	No Change Decrease 1.5%	Increase 5% Increase 5%	Decrease 5% Decrease 5%
Current No Load Starting Full Load Temp. Rise Overload Capacity Magnetic Noise	Increase 10-15% Increase 10-12% Decrease 7% Decrease 3-4% Increase 21% Slight Increase	Decrease 10-12% Decrease 10-12% Increase 11% Increase 6-7% Decrease 19% Slight Decrease	Decrease 5-6% Decrease 5-6% Slight Decrease Slight Decrease Slight Decrease Slight Decrease	Increase 5-6% Increase 5-6% Slight Increase Slight Increase Slight Increase Slight Increase
Efficiency Full Load	Increase 0.5-1.0%	Decrease 2%	Slight Increase	Slight Decrease
Power Factor	Decrease 3%	Increase 1%	Slight Increase	Slight Decrease

OVERLOAD

Standard motors are designed to withstand overload up to 1.6 times their rated torque for 15 Seconds without stalling or abrupt change in speed at rated supply conditions.

RATED SPEED / SLIP

The rated speed is the speed at which the motor runs with rated load. The slip is the difference between the synchronous speed and the rated speed of the motor expressed as a percentage of the synchronous speed.

Where synchronous speed $N_s = 120 \times f / p$
 Where f = frequency of the supply system
 And p = No. Of poles

Normally, for partial loads, slip varies proportionally with output.

RATED CURRENT

It is the current drawn by the motor when running with rated load and the rated supply conditions. The rated current given in performance data are for 415v supply. For motors designed to suit other voltages, the rated current (approximate) is given by

$$I = (V_r / V) \times I_r$$

Where I_r = rated current at rated voltage V_r .

I = rated current at rated voltage V .

The current drawn by a motor varies with the load, though no linear relationship exists.

LOCKED ROTOR CURRENT

(Starting Current)

This is the current drawn by the motor at the time of starting when started on DOL. It is expressed as % age of the rated current of the motor.

The starting current varies proportionately with voltage from its rated value within the permissible limits.

SPEED TORQUE CHARACTERISTICS

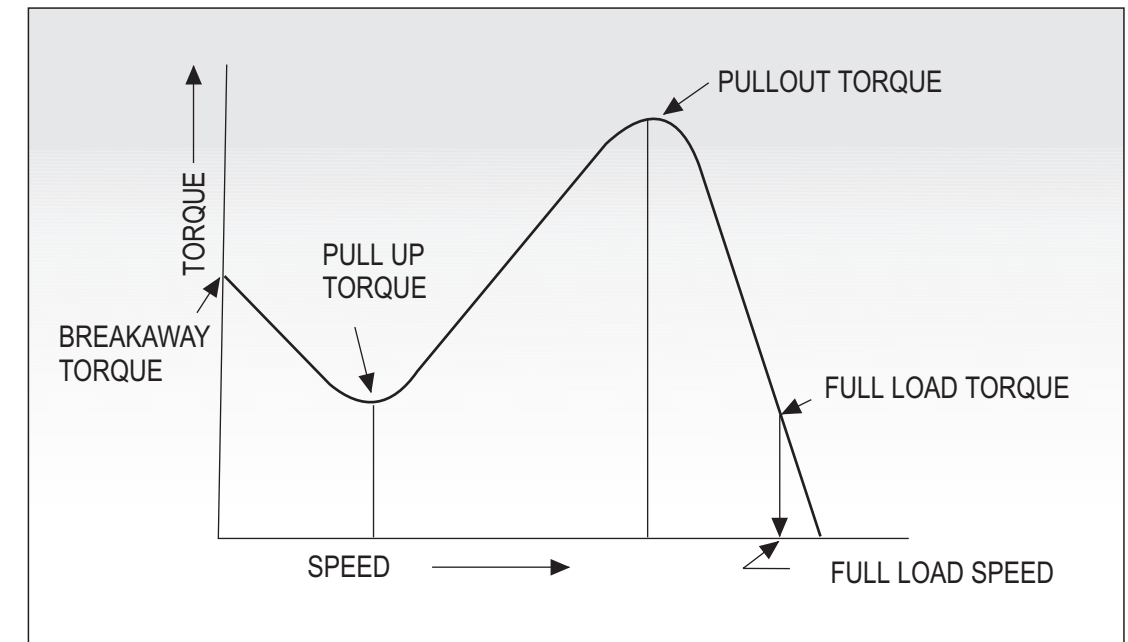

If the voltage varies from its rated value within the permissible limits, the starting, pull-up and pull-out torques vary as the square of the voltage.

Speed Torque Characteristics

Typical Speed Torque characteristics for few applications are shown below:

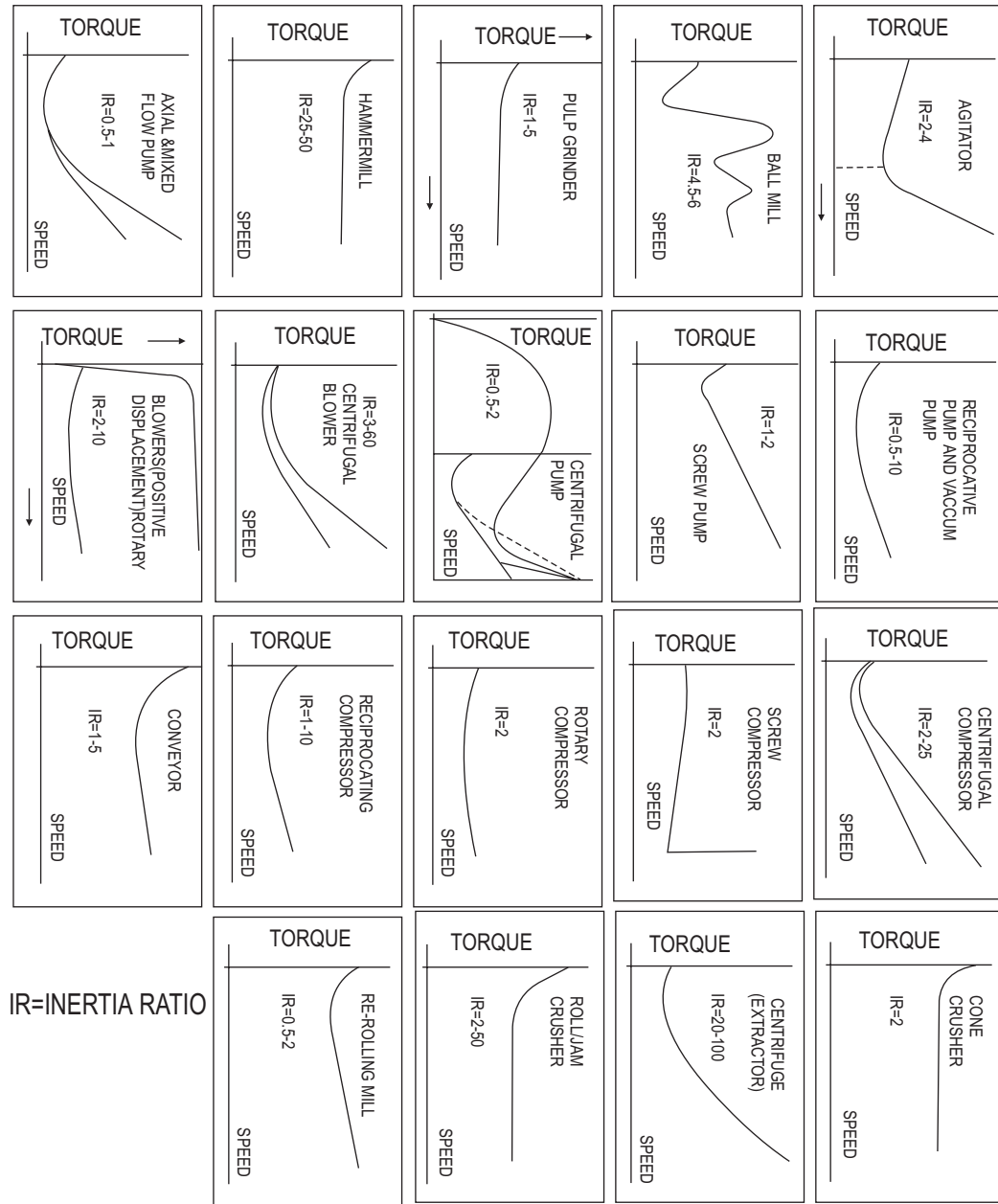

IR=INERTIA RATIO

Note: These characteristics are exemplary and the values of Torque, Inertia Ratio etc. are given based on experience of normal applications. These values should be verified in actual before framing any reference.

LOCKED ROTOR WITHSTAND AND TIME (THERMAL WITHSTAND TIME)

It is the time taken by the motor windings or rotor to reach the maximum limiting temperature, during locked rotor condition, depending upon class of insulation, from either ambient temperature, or rated service temperature.

CALCULATION OF LOCKED ROTOR WITHSTAND TIME FOR STATOR		CALCULATION OF LOCKED ROTOR WITHSTAND TIME FOR ROTOR:	
Limiting Temperature		Limiting Temperature	
Class B Insulation	185°C	For normal applications: 450°C	
Class F Insulation	210°C	For hazardous areas, respective temperature class to be considered.	
Class H Insulation	235°C		
Locked rotor withstand time (cold)		Locked Rotor Withstand time (cold)	
= (Limiting temp. - Amb Temp.) / 0.0065 x 0.85 x j ²		= (Limiting Temp. - Amb. Temp.) / * x 0.85	
		Where * = (T st/ Tr) x P ₂ / (J x W ₂)	
Locked rotor withstand time (hot)			
= (Limiting temp. - Max. Permissible Temp.) / (0.0065 x 0.85 x j ²)		Tst/ Tr = Starting torque to full load torque ratio	
		P ₂ = Specific heat of rotor conductors in Joules/kg / °C	
		W ₂ = Weight of rotor conductors in kg.	
		J = Starting current density	
		Locked Rotor withstand time (hot)	
Where j = Starting Current Density & Max. Permissible Temp.		= (Limiting temp. - permissible rotor temp.) / * x 0.85	
= 120°C for Class B Insulation			
= 140°C for Class F Insulation			
= 165°C for Class H Insulation			

Starting Time

It is the time taken by a motor to come to its rated speed, when connected to load.

Starting time depends upon:

- Total Inertia of the system i.e. GD² of load referred to motor shaft speed plus motor GD².
- Torque speed curve of the motor.
- Torque speed curve of the load

Starting time should be lower than thermal withstand time for safe operation of the motor

Calculation of starting time

The starting time can be calculated approximately by the following formulae

$$t_a = \frac{K \times \text{Total GD}^2}{\text{Output} \times (K_1 - K_2)}$$

Where t_a = acceleration time (starting time) in secs.
 K = 24.66 for 2 pole (3000 synchronous RPM)
 = 6.165 for 4 pole (1500 synchronous RPM)
 = 2.74 for 6 pole (1000 synchronous RPM)
 = 1.541 for 8 pole (750 synchronous RPM)

Total GD² = GD² of motor + GD² of load in kgm²

Output = Output of motor in kw

$$K1 = \frac{\text{Breakaway torque}}{\text{Full load torque}}$$

$$K2 = \frac{\text{Load torque}}{\text{Full load torque}}$$

=0.3 for fans, blowers, pumps

= 1.0 for other applications liker cranes, hoists, conveyors.

The starting time can be more accurately determined by knowing the load torque speed curve and superimposing it on the motor torque speed curve.

Example

Consider a 2.2 KW 6 pole motor in frame 112 M for driving centrifugal fan.

Motor GD² = 0.048 kgm² load GD² = 4.0 kgm²

Breakaway Torque of the motor =2.0 full load torque

The starting time would then be calculated as follows:

$$t_a = \frac{K \times \text{Total GD}^2}{\text{Output (KW)} \times (K1-K2)}$$

$$= \frac{2.74 \times (0.048 + 4.0)}{2.2 \times (2.0 - 0.3)}$$

$$= 2.895, \text{ say } 2.9 \text{ seconds.}$$

GENERAL TOLERANCES ON ELECTRICAL PERFORMANCE (AS PER IS 325)

SR. NO.	ITEM	TOLERANCE
1.	EFFICIENCY a. By summation of losses Motors Upto 50 kw Motors above 50 kw b. By input output test	- 15 percent of (1-EFF) - 10 percent of (1-EFF) - 15 percent of (1-EFF)
2.	Power factor	-1/6 of (1-cosφ) min 0.02 and max 0.07
3.	Slip at full load and working temp.	+20 percent of guaranteed Slip.
4.	Breakaway starting current of SCR induction motors with short-circuited rotor and with any specified starting apparatus.	+20 percent of the guaranteed Starting current (no lower limit)
5.	Breakaway torque	-15 percent to +25 proper cent of the guaranteed torque (+25 percent may be exceeded by agreement)
6.	Pull out torque	-10percent of the guaranteed torque except that after allowing for this tolerance the torque shall not be less than 1.6 to 1.5 times the rated torque

ACCESSORIES

When required, the accessories which are provided with a motor, are thermistors, space heaters, sockets for customer's cable etc. compression glands; RTD and BTD for 280/315 motors.

THERMISTORS

These are semi conductor devices, which have a property of suddenly changing their resistance at a definite temperature known as 'curie point'. Thermistors that may be provided on the motors are those having 'Positive Temperature Coefficient' (PTC); where the resistance suddenly increases at a 'Curie Point'. The thermistors generally provided are at 130°C (PTC 130) for Class B temperature rise, 150°C (PTC 150) For class F motors.

A combination of different ratings of thermistors can be provided in same motor for 'Alarm & Trip' facilities for frame 160 and above only.

MODE OF OPERATION

Three thermistors connected in series are placed inside each of the phase windings of the motor. This gives protections against single phasing and /or over heating due to excess load on the motor.

During normal operation the thermistors carry a current of few mA, which is sufficient to actuate a relay in control unit. This in turn allows the contactor operating coil to hold the starter in the 'Run position. If the winding of the motor heats up to such an extent so as to bring the temperature of the thermistors up to 'Curie point'. The increase in

the resistance causes the relay to open and the contactor to disconnect the motor supply, # The leads of thermistors are terminated in the auxiliary terminal box for frames 200 & above.

For frame AD 63 to AD 100L and D80 the thermistors terminals are brought on the same terminal block as that of main windings.

SPACE HEATERS

These are provided over the windings of the motor .The main function of heaters, is to heat the windings when motor is in idle condition or kept in storage , in order to prevent moisture or dew settling over the windings and thereby reducing the insulation resistance CAUTION-Supply to the heaters must be switched off before switching on the motor. The motors are provided with space heaters of ratings 25w, 40w, 50w, or 60w 240 V single phase depending on the frame size. Like thermistors the space heater leads are also brought in the main terminal box up to frame 180 and in a separate auxiliary terminal box for frames 200 and above.

GUIDE FOR MOTOR PROTECTION-FUSE RATINGS

In addition to the starters (DOL or Star / Delta) being used to protect motors from overload and under voltage, the motors are also to be provided with back up fuse protections of suitable ratings. The table below gives general guidelines for selection of the fuse ratings.

GUIDE FOR MOTOR PROTECTION- FUSE RATINGS

In addition to the starters (DOL or Star / Delta) being used to protect motors from overload and under voltage, the motors are also to be provided with back up fuse protections of suitable ratings. The table below gives general guidelines for selection of the fuse ratings.

BACK-UP FUSE SELECTION CHART

D.O.L STARTING OF MOTORS																						
MOTOR OUTPUT	KW	0.37	0.55	0.75	1.1	1.5	2.2	3.7	5.5	7.5	9.3	11	15	18.5	22	26	30	37	45	55	75	90
FULLLOAD CURRENT	HP	0.5	0.75	1.0	1.5	2.0	3.0	5.0	7.5	10	12.5	15	20	25	30	35	40	50	60	75	100	125
OVERLOAD RELAY RANGE	A	1.0	1.3	1.9	2.6	3.7	4.8	7.8	11.2	15	18	21	27	33	39	47	53	65	78	96	131	156
RECOMMENDED BACKUP PROTECTION FUSE RATING	A	0.5-1	1-2	1-2	1.5-3	2-4	3-6	6-12	6-12	10-16	18-24	18-24	16-32	24-45	32-63	32-63	32-63	50-90	50-90	70-110	90-135	140-170
RECOMMENDED BACKUP PROTECTION FUSE RATING	A	4	6	6	6	10	16	16	25	25	32/35	32/35	50	63	80	100	100	160	160	200	200	250

STAR DELTA STARTING OF MOTORS																						
MOTOR OUTPUT	KW	2.2	3.7	5.5	7.5	9.3	11	15	18.5	22	26	30	37	45	55	75	90	110	132			
FULL LOAD LINE CURRENT*	HP	3.0	5.0	7.5	10	12.5	15	20	25	30	35	40	50	60	75	100	125	150	180			
FULL LOAD PHASE CURRENT*	A	4.8	7.8	11.2	15	18	21	27	33	39	47	53	65	78	96	137	156	185	220			
OVERLOAD RELAY RANGE	A	2.8	4.5	6.5	9	11	12.7	16.8	20.2	23.2	26.9	30.6	37.5	46.4	54.5	74	88	107	127			
RECOMMENDED BACKUP PROTECTION FUSE RATING	A	3-6	6-12	6-12	10-16	18-24	18-24	16-32	24-45	24-45	32-63	32-63	50-90	50-90	70-110	90-135	140-170					
RECOMMENDED BACKUP PROTECTION FUSE RATING	A	10	16	16	25	25	25	50	50	63	63	63	80	100	125	160	200	200	250			

* Average value for 6 & 8 pole motors

POWER FACTOR IMPROVEMENT CHART

Ratings of capacitors in KVAR required for given degree of power factor correction per kW of load
INITIAL POWER FACTOR V/S KVAR OF CAPACITOR

Initial Power Factor	Correction to				
	0.85	0.90	0.95	0.98	Unity
0.50	1.112	1.248	1.403	1.529	1.732
0.51	1.066	1.202	1.357	1.483	1.686
0.52	1.024	1.160	1.315	1.441	1.644
0.53	0.980	1.116	1.271	1.397	1.600
0.54	0.939	1.075	1.230	1.356	1.559
0.55	0.899	1.035	1.190	1.316	1.519
0.56	0.860	0.996	1.151	1.277	1.480
0.57	0.822	0.958	1.113	1.239	1.442
0.58	0.785	0.921	1.076	1.202	1.405
0.59	0.748	0.884	1.039	1.165	1.368
0.60	0.714	0.849	1.005	1.131	1.334
0.61	0.679	0.815	0.970	1.096	1.299
0.62	0.645	0.781	0.936	1.062	1.265
0.63	0.613	0.749	0.904	1.030	1.233
0.64	0.580	0.716	0.871	0.997	1.200
0.65	0.549	0.685	0.840	0.966	1.169
0.66	0.518	0.654	0.809	0.935	1.138
0.67	0.488	0.624	0.779	0.905	1.108
0.68	0.459	0.595	0.750	0.876	1.079
0.69	0.429	0.565	0.720	0.840	1.049
0.70	0.400	0.536	0.691	0.811	1.020
0.71	0.372	0.508	0.663	0.783	0.992
0.72	0.343	0.479	0.634	0.754	0.963
0.73	0.316	0.452	0.607	0.727	0.936
0.74	0.289	0.425	0.580	0.700	0.909
0.75	0.263	0.398	0.553	0.673	0.882
0.76	0.235	0.371	0.526	0.652	0.855
0.77	0.209	0.345	0.500	0.620	0.829
0.78	0.183	0.319	0.473	0.594	0.803
0.79	0.156	0.292	0.447	0.567	0.776
0.80	0.130	0.266	0.421	0.541	0.750
0.81	0.104	0.240	0.395	0.515	0.724
0.82	0.078	0.214	0.369	0.489	0.698
0.83	0.052	0.188	0.343	0.463	0.672
0.84	0.026	0.162	0.317	0.437	0.645
0.85	-	0.136	0.291	0.417	0.620
0.86	-	0.109	0.264	0.390	0.593
0.87	-	0.083	0.238	0.364	0.567
0.88	-	0.054	0.209	0.335	0.538
0.89	-	0.028	0.183	0.309	0.512
0.90	-	-	0.155	0.281	0.484

Example: Initial Power Factor: 0.76

Correction Desired: 0.9

Capacitor KVAR required per KW load from chart: 0.371

Load (e.g. from meter reading): 140KW

Capacitor KVAR required: 0.37x140 =51.8 KVAR =50 KVAR.

TEFC MOTORS

DERATING FACTORS: The deration factors applicable under different conditions are given below:

Operating conditions:

A: 415 V +/- 6%, 50Hz +/-3%

B: 415V +/-10%, 50Hz +/- 5%

Table A: permissible output as % of standard output for different Ambient temperatures

Ambient Temp.	40°	45°	50°	55°	60°	65°
A	100%	100%	93.3%	86.7%	80%	73%
B	100%	100%	92%	85%	78%	70.5%

Table B: Permissible output as % of standard output at different altitude

Altitude in Mtrs Above MSL	1000	1500	2000	2500	3000	3500	4000
A	100%	98%	93%	87%	82%	78%	73%
B	100%	95%	90%	84%	78%	75%	70%

Table C: Permissible output as % of standard output for different % of unbalance in Voltage

% Unbalance	1%	2%	3%	4%	5%
A	100%	100%	95%	82.5%	75%
B	100%	95%	90%	78%	70%

Table D: Permissible output as % of standard output at different voltages

Voltage	100%	90%	85%	80%	70%
40° C Ambient	100%	100%	90%	85%	75%
45° C Ambient	100%	90%	85%	80%	70%

Table E: Permissible output as % of standard output * for different duties

	S2			S3			S4-S9
	60Min	30Min	10Min	60%CDF	40%CDF	25%CDF	
A	110%	120%	130%	110%	110%	130%	Special Design Required
B	100%	115%	120%	100%	105%	120%	

* Standard motors for above permissible output will have starting and breakdown torque proportionately reduced as % of FLT, hence these will be suitable only for application requiring low starting torque and are to be started Direct-On-Line.

NOTE: When motor is subjected to two or more variations in above mentioned conditions, then all the appropriate factors are to be multiplied to arrive at permissible output

THERMAL WITHSTAND TIME

(OF STANDARD TEFC MOTORS OPERATING AT RATED VOLTAGE AND FREQUENCY)

POLE FRAME	2		4		6		8	
	Hot	Cold	Hot	Cold	Hot	Cold	Hot	Cold
63	10	20	15	30	.	-	-	-
71	10	20	10	20	10	20	15	30
80	10	20	10	20	10	20	15	30
90	10	20	10	20	10	20	15	30
100	8	16	8	16	10	20	10	20
112	8	16	8	16	10	20	10	20
132	8	16	8	16	10	20	10	20
160	10	22	10	22	10	22	10	22
180	10	22	10	22	10	22	10	22
200	12	27	12	27	12	27	12	27
225	12	27	12	27	12	27	12	27
250	12	27	12	27	12	27	12	27
280	15	33	15	33	15	33	15	33
315	15	33	15	33	15	33	15	33
355	15	33	15	33	15	33	15	33

Cold - Ambient Temp. 45 ° C

Hot - Max. permissible Temp. 120 ° C

Limiting Temperature - upto 185°C for class "B" Insulation
upto 210°C for class "F" Insulation

TOTALLY ENCLOSED SQUIRREL CAGE INDUCTION MOTORS

AIR STREAM RATED MOTORS

These are totally enclosed motors without normal fan of TEFC motors. The applications of these motors are for fans, blowers, exhausts etc. wherein the fan or impellers acting as load suck air from DE or NDE, that flows over the motor body. This air provides the cooling for the motors. Hence, it is necessary that the velocity of the air flowing over the motor should not fall below the velocity of air due to normal fan of a TEFC motor. The minimum air velocity is given in the table below.

OUTPUT VS. AVERAGE AIR VELOCITY

FRAME SIZE	2 POLE		4 POLE		6POLE		8POLE	
	KW O/P	AIR VELOCITY (AV) M/S	KW O/P	AIR VELOCITY (AV) M/S	KW O/P	AIR VELOCITY (AV) M/S	KW O/P	AIR VELOCITY (AV) M/S
80	.75	10	.75	7.5	.55	6.5	.37	5.0
90	2.2	12.5	1.5	9	1.1	7.5	.55	6
100	3.7	15	2.2	10	1.5	8	1.1	7
112	5.5	16.5	3.7	11	2.2	9	1.5	7.5
132	9.3	18	7.5	12	5.5	9.5	3.7	8
160	18.5	19	15	12.5	11	10.5	7.5	8.5
180	22	20	22	13.5	15	11	11	9
200	37	21	30	14	22	11.5	15	9.5
225	45	22	45	14.5	30	12	22	10
250	55	23	55	15	37	12.5	30	10.5

NON-VENTILATED MOTORS

These are totally enclosed motors, where the heat generated is dissipated by the body alone, with no provision for cooling. As these motors are naturally cooled, the ratings are required to be offered in higher frames.

MULTI-SPEED MOTORS

Table one indicates ratings of Multispeed motors for polarity ratio of 2/4p, 4/6p, 4/8p, 6/8p, and 6/12p. These are of tapped or PAM winding construction. For other ratios, please refer to us. Also three speed and four speed motors are offered as per customer's requirement.

The frame/output relationship in table one is confirmed subject to knowing

- Complete application details.
- Duty cycle/loading cycle
- Method of braking
- Load GD² referred to motor speed.

Motors required for Multispeed/two speed operations are designed with two types of winding techniques

- Tapped winding (also called Dahlander winding) where the two speeds are in ratio of 2:1
- Separate windings one for each speed, when the output speeds are other than 2:1 ratio. The latter results in considerable reduction in HP output.

Note: Motors will be suitable for DOL Starting only.

**DUAL SPEED MOTORS
(FRAME V/S kW OUTPUT) (Single winding)
CONSTANT TORQUE APPLICATION**

FRAME	2/4	4/6	4/8	6/8	6/12
ND90S**	0.9/0.45	0.37/0.25 #0.84/0.55	0.37/0.19 #0.67/0.37	---	---
ND90L**	1.2/0.6	0.75/0.55 #1.1/0.75	0.55/0.28 #1.1/0.55	---	---
ND100L	2.4/1.2	1.1/0.82 #2.2/1.5	1.1/0.55 #1.65/1.0	---	---
ND112M	3.7/1.86	2.2/1.6 #3.0/2.2	1.94/0.97 #2.2/1.5	---	---
ND132S	5.2/2.6	3.7/2.5 #4.3/2.8	3.0/1.5 #3.3/2.2	---	---
ND132M	6.0/3.0	5.5/4.1 #7.5/5.0	4.5/2.2 #4.5/3.0	---	---
ND160M	11.0/7.5	7.5/5.5	7.5/3.7	5.5/3.7	---
ND160L	15.0/11.0	11.0/7.5	11.0/5.5	7.5/5.5	---
ND180M	18.5/15.0	13.0/9.3	12.5/6.3	9.3/6.3	---
ND180L	20.0/17.0	15.0/11.0	15.0/7.5	11.0/7.5	---
ND200L	26.0/22.0	22.0/17.0	22.0/11.0	15.0/11.0	---
ND225S	30.0/26.0	27.5/18.5	27.5/13.8	18.5/13.8	---
ND225M	37.0/33.5	33.5/22.0	33.5/16.8	22.0/16.8	---
ND250M	52.0/41.0	45.0/30.0	45.0/22.0	30.0/22.0	---
ND280S	---	*	45.0/37.0	---	---
ND280M	---	45.0/30.0	55.0/28.0	---	---
ND315S	---	55.0/37.0	75.0/25.0	---	---
ND315M	---	*	75.0/45.0	---	---
ND315L	---	132.0/90.0	132.0/67.0	---	---
	---	---	110.0/55.0	---	---

** For 4 / 8 pole Frames will be D90S/L
- For ratings marked as *, refer to Division

DUAL VOLTAGE MOTORS

Motors can be offered for dual voltage operation. Such motors are so designed that they work satisfactorily on both the voltages, but motor may not give optimum performance at both the voltage

Two kinds of dual voltage motors are offered.

Motors operating at voltages in a ratio of 1: 1.73 or $\sqrt{3}$

Entire range of motors can be suitably wound to operate in such voltage combinations. This method is also known as Delta-Star reconnections. Motor is DELTA connected at lower voltage and STAR connected at higher voltage. 6 lead terminal blocks is fitted and suitable connecting links are provided (if required). These motors are suitable for standard supply variations. Example:

A motor designed for 380V operation (STAR connection) can also be run with 220V supply (MESH connection)

$$\frac{380}{220} = 1.73$$

Hence merely by changing the position of connecting links, dual voltage operation can be achieved. Alternatively this can also be performed with the help of a suitable starter.

Motors operating on voltage in a ratio of 1: 2

This phenomenon involves Series Parallel connections in the windings. Motors are DELTA wound at both the voltages. Such motors have 9 leads (for DOL starting at both voltages) coming out from stator windings.

Slipping motors and Multispeed cannot be offered for dual voltage operations.

Flameproof motors are generally not offered with series parallel reconnection because of limitations of terminal studs inside the terminal box. However specific cases may be sent to Division for scrutiny.

MOTORS FOR VARIOUS APPLICATIONS

Sector	Type of motor	Name of Major Customer
Compressor	Motors with service factors	Ingersoll Rand, KG Khosla, Atlas Copco, Blue Star, Alfa Laval, ELGI, York Refrigeration
Ventilator & Allied Equipment		Flakt India, Blue Star Air Conditioning Corporation, Paharpur Cooling Towers, Voltas
Pump		Greaves, KSB Pumps, BPCL, Beacon Weir, SULZUR, KBL, Kirloskar Ebbara, Mather & Platt
Marine	Marine Duty, Shock Grade	Mazagaon Dock, Flakt, BEST & Crompton GRSE, Goa Shipyard, BE Pumps, Alekton Engg.
Material Handling	Conveyor Crane/Host	L & T, McNally & Bharat, Mukund, Elecon Engg, Rewa Engg, TRF
Lift	High Torque Motors	City Lift. ECE, Otis Elevators
M/C Tools	M/C Tool Applications	HMT, GSMTC, BEMCO M/c Press
Gear Box		Power Build, New Allenburry Works, Essential Power Transmission, DYNASPEED
Railway	Blower, Auxilliary Motors for compressor exhaust	CLW, ELGI, ACCEL, FLAKT, ACCO
Power		NTPC, DCL, BHEL, DESEIN, MSEB, INDURE, GEB, TNBB, PSEB, WBSEB, RAPP KPCL, NPC, DPG.
Chemical		Supreme Petro, Finolex, HPCL
Petrochemicals	Flameproof Type 'e'	IOCL, IPCL, ONGC, HALDIA PETRO MRPL, SPIC, RELIANCE, ESSAR
Fertilisers	Type 'e', Type 'n'	RCF, FACT, GNFC, GSFC, NFL, IFFCO
Cement		L & T, Indian Rayon, Vikram Cement, Rajashree Cement, Grasim Industries, Gujrat Himalaya Gujrat Ambuja, Sanghi Cement, Madras Cement Vishakha Cement, Orient Cement, India Cement
Steel Plant		Vizag Steel Plant, Bokaro Steel Plant, Bhilai Steel Plant, TISCO, Rourkela Steel Plant, Durgapur Steel Plant, SAIL, Lloyd Steel, Jindal Steel
Sugar		ISGEC, WALCHANDNAGAR, KRUPP, NHEC, FULLER KCP

TESTING OF MOTORS

All motors are tested in accordance with IS 325.

TYPE TESTS

The following tests are carried out on one motor in a batch production or on motors specially required to be type tested as per customer's requirement. All tests included in routine tests and following additional tests are carried on the motor.

- a. Measurement of stator resistance
- b. No Load Test
- c. Locked rotor test at reduced voltage and measurement of current, power input and torque of motors.
- d. Full load reading of voltage, current, power input and slip.
- e. Temperature rise test The temperature rise of the motor after being run on full load till steady state is reached is determined by
 - i. Thermometer method
 - ii. By resistance method
- f. Momentary overload test
- g. Insulation resistance test
- h. High voltage test

ROUTINE TESTS

The following are the routine tests carried out on each and every motor.

- a. Measurement of resistance
- b. Insulation resistance test.
- c. Motors are tested at 1/3 times the rated voltage for checking the ability of the motor to run up to the full speed, when switched in either direction.
- d. No load test. This test is carried out at rated voltage and the readings for current, RPM & power input are noted.
- e. Locked rotor test This test is carried at a reduced voltage by passing the full load current and the readings for current and power input are noted.
- f. High voltage test

NOTE: The meters used for noting the above readings have class 0.5 class accuracy.

OTHER TESTS

Apart from the above tests mentioned in the Indian Standards, following additional tests can be offered.

- a. Over speed test Running of motor at 1.2 times the maximum rated speed for 2 Mins at no load.
- b. Vibration test Carried out as per IS:12075
- c. Noise level of the motors measured as per IS:12065
- d. Test for degree of protection as per IS 4691 (2nd numeral only)

ORDERING INFORMATION

At the time of sending an enquiry or placing an order, kindly furnish following data (as much as possible)

	CUSTOMER						
1	FRAME SIZE						
2	APPLICATION						
3	ZONE/DIV (IN CASE HAZARDOUS AREA)						
4	ENCLOSURE GROUP (FOR TYPE Ex 'd')						
5	TEMP CLASS (FOR TYPE e/N/Ex 'd')						
6	ANY SPECIFIC STATUTORY / REGULATORY REQUIREMENTS						
7	REFERENCE TO INDIAN / INTERNATIONAL STD.	IS:325 IS:9628	IS:2148 IS:7389	IS:6381	IF OTHER SPECIFY		
8	ANY CUST /CONSULTANT SPECS.						
9	TYPE OF ENCLOSURE	TEFC TYPE p	SPDP TYPE e	TYPE d TYPE n	IF OTHER SPECIFY		
10	TYPE OF ROTOR	SCR	SR: WIRE or BAR	IF OTHER SPECIFY			
11	TYPE OF DUTY	S1 S5	S2 S6	S3 S7	S4 S8	S9	IF OTHER SPECIFY
12	% CDF						
13	NO.OF STARTS/HR	6, 10, 90, 150, 300, 600, 900					
14	TYPE OF BRAKING /NO.OF. REVERSAL						
15	LOAD GD ²						
16	DEGREE OF PROTECTION	IP54 IP22	IP55 IP23	IP21	IF OTHER SPECIFY		
17	METHOD OF COOLING	FAN AIR STREAM	NATURAL	BLOWER	IF OTHER SPECIFY		
18	MOUNTING						
19	FREQUENCY IN Hz & VARIATION	50 ± 5%			IF OTHER SPECIFY		
20	OUTPUT IN KW						
21	RATED VOLTAGE AND VARIATION	415 ± 10%			IF OTHER SPECIFY		
22	CLASS OF INSULATION				F	H	
23	APPROX SPEED, IN RPM OR POLARITY						
24	DIR OF ROT VIEWED FROM DE	BI DIR	ACW	CW			
25	DESIGN AMB TEMP.						
26	% REL HUMIDITY						
27	MAX. PERMISSIBLE TEMPRISE	BY RES			IF OTHER SPECIFY		
28	ALTITUDE AT SITE IN METER	<1000M			IF OTHER SPECIFY		
29	PERFORMANCE REQUIREMENT		FL	3 /4 FL	1 /2FL		
a.	EFFICIENCY						
b.	POWER FACTOR						
c.	LOAD CURRENT						
d.	STARTING CURRENT						
e.	STARING TORQUE						
f.	RV/RA						
g.	PULL OUT TORQUE						
h.	NOISE LEVEL (OTHER THAN IS:12065)						
i.	VIB LEVEL (OTHER THAN IS:12705)						
j.	ANY OTHER						
30	SYSTEM OF EARTHING, IF ADOPTED						
31	PARTICULARS OF TESTS TO BE CARRIED OUT (OTHER THAN TYPE & ROUTINE AS PROPER IS:325)						
32	METHOD OF STARTING	DOL	Y/D	SOFT START			
		IF OTHER SPECIFY					
33	DRIVE(IF APPLICABLE)	VVVF(* FREQ RANGE)			IF OTHER SPECIFY		
34	DIMENSIONS	STD	IF OTHER SPECIFY				
35	GA DRG.NO (IF NON STD)						
36	METHOD OF DRIVE	BELT		BELT PULL / PULLEY DIA			
		DIRECT		TYPE OF COUPLING			
		OTHER					
37	CABLE SIZE/TYPE						
38	CABLE GLAND (IF REQD)	DCG		MINING	P&S		
39	ACCESSORIES	THERMISTOR					
		SPACE HEATER		BTD	IF OTHER SPECIFY.		
		RTD		IF OTHER SPECIFY			
40	NON STD TREATMENT	ACP		IF OTHER SPECIFY			
41	ANY OTHER SPECIFIC REQUIREMENT						
*	TORQUE OVER ENTIRE FREQUENCY RANGE						

**GUIDE & CHECK POINTS FOR MOTOR SELECTION
MECHANICAL ASPECTS**

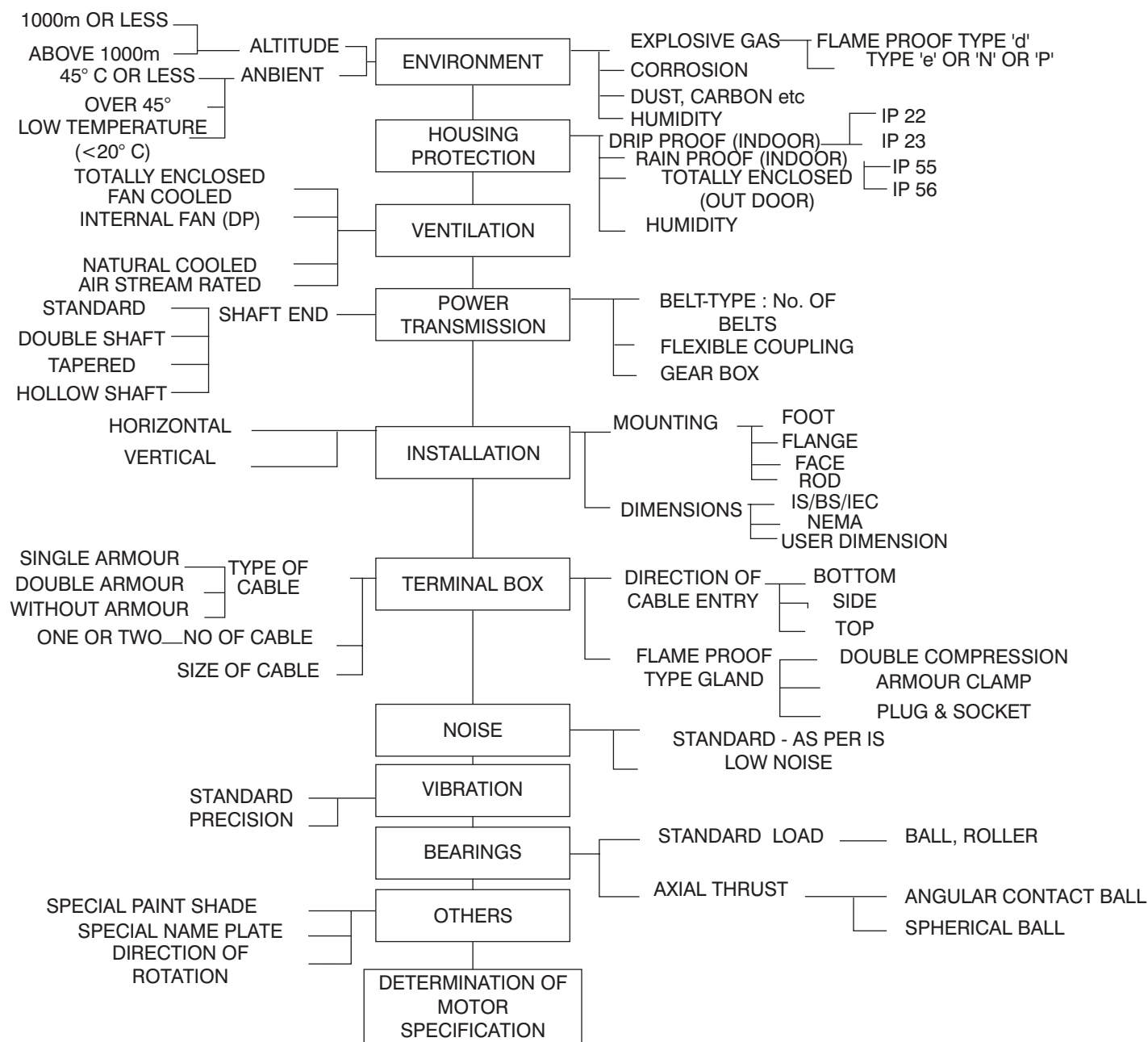

**GUIDE & CHECKPOINTS FOR MOTOR SELECTION
ELECTRICAL ASPECTS**

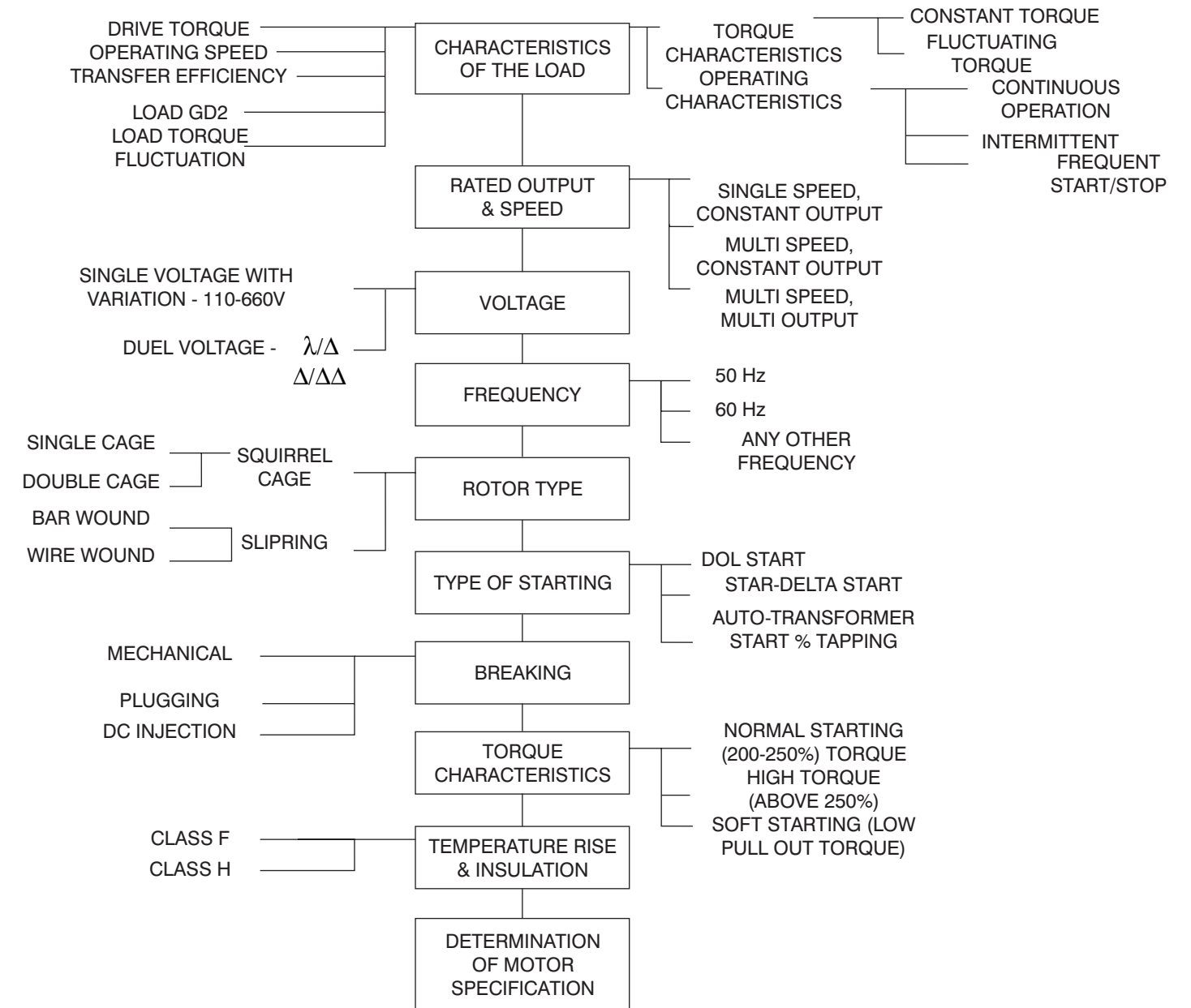

**OUTLINE DIMENSION DRAWING FOR 3 PHASE SQUIRREL CAGE
TEFC FOOT MOUNTED ALUMINIUM BODY INDUCTION MOTORS
FOR AD63 TO AD132 FRAMES**

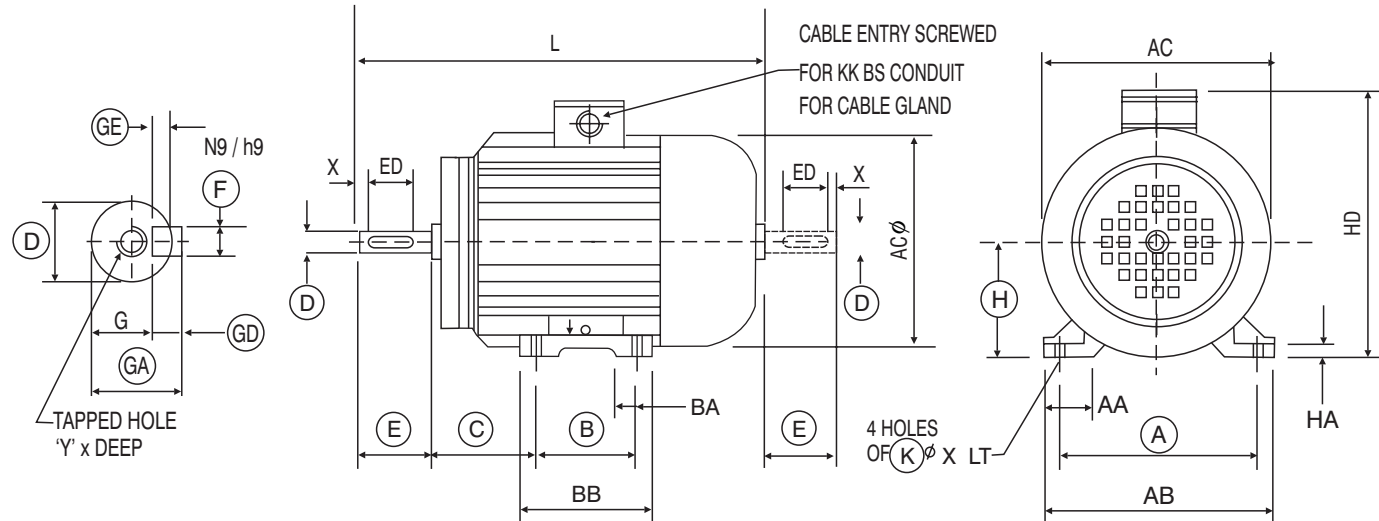

KEY		KEY WAY		SHAFT				FIXING	
GD	F	ED	F	GE	D		H	K	ON
h11	h9		N9	-	k6	j6	-	H14	GR.
6 to 10	3 to 6	3 to 6	8 to 10	upto 3.5	30 to 50	18 to 30	ALL	12	RANGE
-0.090	-0.030	0	-0.036	0	+0.018	+0.009	-0.500	+0.043	TOL.
	-0.036	0.300	+0.200	+0.100	+0.002	-0.003	0	0	
	-0.030	0	-0.036	0	+0.018	+0.009	-0.500	+0.043	
	-0.036	0.300	+0.200	+0.100	+0.002	-0.003	0	0	

FRAME SIZE	FOOT FIXING									SHAFT AND KEY									YxDEEP	OVERALL(MAX)			KK		
	A	B	C	H	AA	AB	BA	BB	HA	K	LT	D	E	ED	F	G	GA	GD		GE	X	AC		L	HD
AD63	100	80	40	63	25.5	122	30	96	9	7φ	-	11	23	18	4	8.5	12.5	4	2.5	2.5	M4 x 10	125	210	160	3/4"
AD71	112	90	45	71	30	136	30	110	9	7φ	-	14	30	25	5	11	16	5	3	2.5	M5 x 12.5	145	250	170	3/4"
AD80	125	100	50	80	28	152	35	125	11	10	14	19	40	27	6	15.5	21.5	6	3.5	-	M6 x 16	165	285	200	3/4"
AD90S AD90L	140	100 125	56	90	40	170	30	126 151	13	10	15	24	50	36	8	20	27	7	4	-	M8 x 19	180	310 335	226	1"
AD100L	160	140	63	100	48	192	35	170	13	12	16	28	60	44	8	24	31	7	4	-	M10x22	200	360	245	1"
AD112M	190	140	70	112	50	222	35	170	13	12	16	28	60	44	8	24	31	7	4	-	M10x22	222	380	270	1"
AD132S AD132M	216	140 178	89	132	52	252	55	178 216	13	12	16	36	80	60	10	33	41	8	5	-	M12x28	260	475	310	1"

1. DIMENSIONS COMPLY WITH IS : 1231 AND ARE IN MM., EXCEPT CONDUIT ENTRY.
2. TERMINAL BOX CAN BE TURNED THROUGH 360° IN STEP OF 90°, EXCEPT FOR FRAME AD80 WHICH HAS TERMINAL BOX INTEGRAL WITH BODY & CABLE ENTRY ON EITHER SIDE.
3. AD63 & AD71 KEY WAY IS CLOSED WHILE FOR AD80 AND ABOVE FRAMES KEYWAY IS OPEN ON SHAFT.
4. ALL DIMENSIONS ARE SUBJECTED TO CONFIRMATION.
5. PLASTIC T.B. IS USED FOR AD63 TO AD80 FRAME, AND AL T.B. FOR AD90 TO AD132 FRAME.

AD6350

**OUTLINE DIMENSION DRAWING FOR 3 PHASE SQUIRREL CAGE
TEFC FLANGE MOUNTED ALUMINIUM BODY INDUCTION MOTORS
FOR AD63 TO AD132 FRAMES**

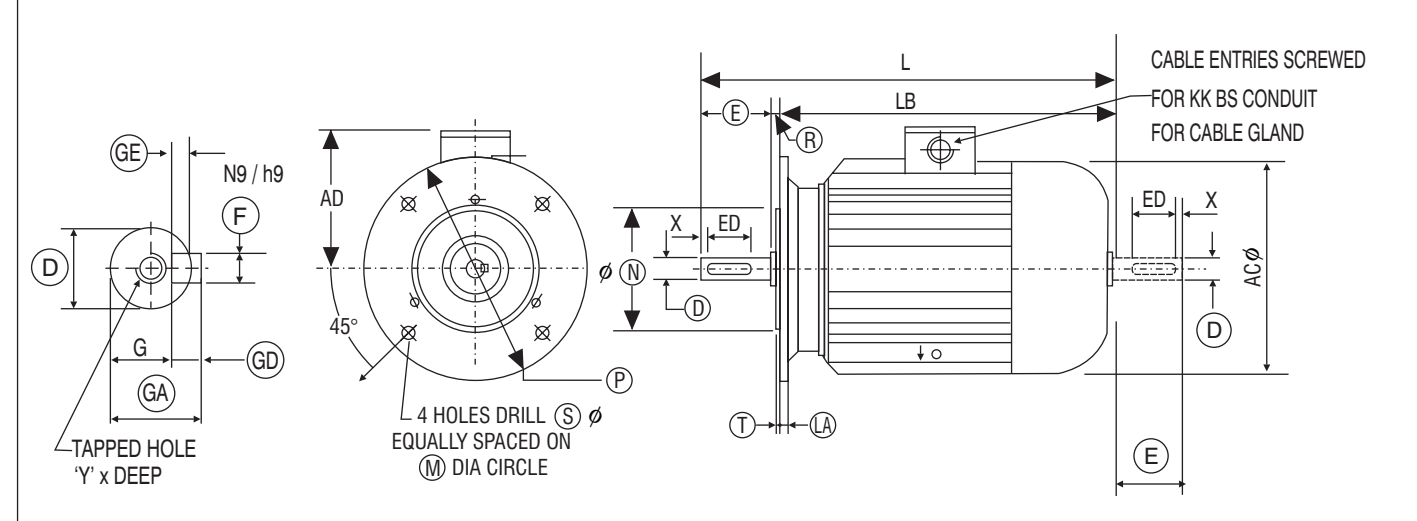

KEY		KEY WAY		SHAFT				FLANGE FIXING	
GD	F	ED	F	GE	D		N	M	ON
h11	h9		N9	-	k6	j6	j6		GR.
6 to 10	3 to 6	3 to 6	8 to 10	upto 3.5	30 to 50	18 to 30	6 to 10	upto 265	RANGE
-0.090	-0.030	0	-0.036	0	+0.018	+0.009	-0.002	+0.300	TOL.
	-0.036	0.300	+0.200	+0.100	+0.002	-0.003	-0.004	-0.300	
	-0.030	0	-0.036	0	+0.018	+0.009	-0.004	-0.300	
	-0.036	0.300	+0.200	+0.100	+0.002	-0.003	-0.004	-0.300	

FRAME SIZE	FLANGE FIXING							SHAFT AND KEY									YxDEEP	OVERALL(MAX)				KK
	M	N	P	R	S	T	LA	D	E	ED	F	G	GA	GD	GE	X		AC	L	LB	AD	
AD63D	115	95	140	0	10	3	9	11	23	18	4	8.5	12.5	4	2.5	2.5	M4x10	125	220	197	100	3/4"
AD71D	130	110	160	0	10	3.5	9	14	30	25	5	11	16	5	3	2.5	M5x12.5	145	250	220	100	3/4"
AD80D	165	130	200	0	12	3.5	10	19	40	27	6	15.5	21.5	6	3.5	-	M6x16	165	285	245	120	3/4"
AD90SD AD90LD	165	130	200	0	12	3.5	10	24	50	36	8	20	27	7	4	-	M8x19	180	310 335	260 285	140	1"
AD100LD AD112MD	215	180	250	0	15	4	11	28	60	44	8	24	31	7	4	-	M10x22	200 222	360 380	300 320	150 158	1"
AD132SD AD132MD	265	230	300	0	15	4	11	38	80	60	10	33	41	8	5	-	M12x28	260	475	395	178	1"

1. DIMENSIONS COMPLY WITH IS : 2223 AND ARE IN MM. EXCEPT CONDUIT ENTRY.
2. TERMINAL BOX CAN BE TURNED THROUGH 360° IN STEP OF 90°, EXCEPT FOR FRAME AD80 WHICH HAS TERMINAL BOX INTEGRAL WITH BODY & CABLE ENTRY ON EITHER SIDE.
3. AD63 & AD71 KEY WAY IS CLOSED WHILE FOR AD80 AND ABOVE FRAMES KEYWAY IS OPEN ON SHAFT.
4. ALL DIMENSIONS ARE SUBJECTED TO CONFIRMATION.
5. PLASTIC T.B. IS USED FOR AD63 TO AD80 FRAME, AND AL T.B. FOR AD90 TO AD132 FRAME.

AD6340

OUTLINE DIMENSION DRAWING FOR 3 PHASE SQUIRREL CAGE TEFC FOOT MOUNTED CAST IRON BODY INDUCTION MOTORS FOR ND90 TO ND132 FRAMES

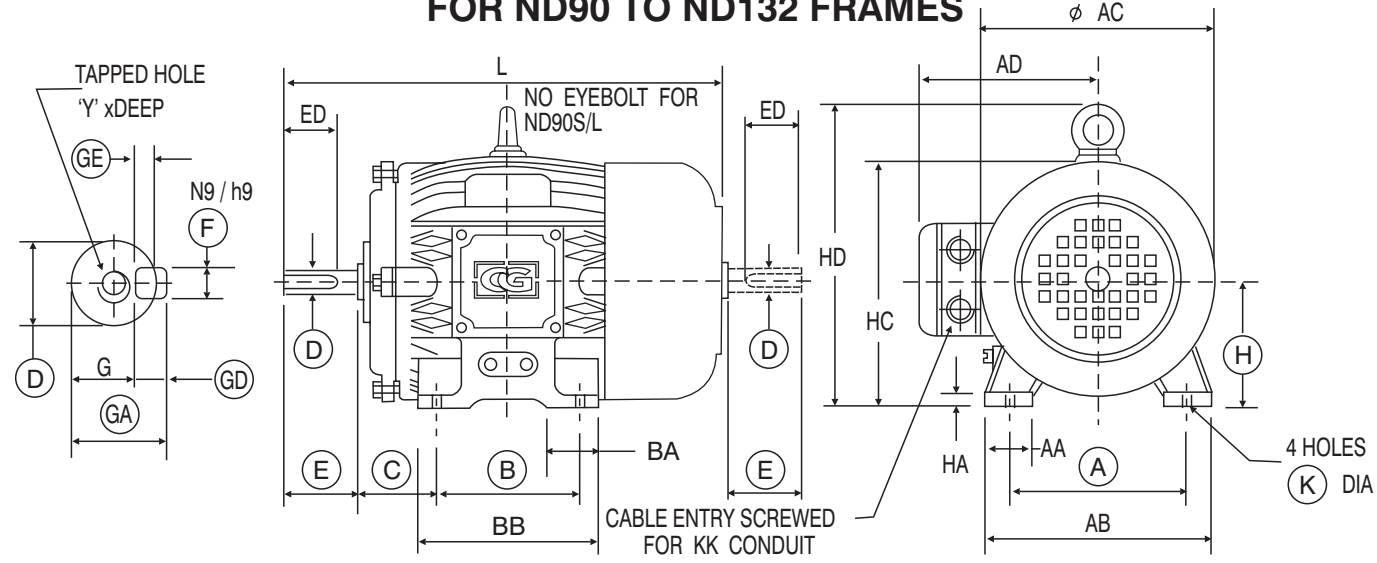

KEY		KEY WAY		SHAFT				FIXING	
GD	F	ED	F	GE	D		H	K	DN
h9	h9	-	N9	-	k6	j6	-	H14	GR.
6 to 10	3 to 6	30 to 80	4 to 6	4 & above	30 to 50	18 to 30	ALL	12	RANGE
-0.090	-0.030	+0.300	+0.030	+0.200	+0.018	+0.009	-0.500	+0.043	TOL.

FRAME SIZE	FOOT FIXING									SHAFT AND KEY								OVERALL(MAX)							
	A	B	C	H	AA	AB	BA	BB	K	D	E	ED	F	G	GA	GD	GE	YxDEEP	AD	AC	L	HC	HD	HA	KK
ND90S ND90L	140	100 125	56	90	35	168	40	127 152	10	24	50	36	8	20	27	7	4	M8 x 19	150	195	315 340	185	-	13	1"
ND100L	160	140	63	100	36	192	45	170	12	28	60	44	8	24	31	7	4	M10 x 22	160	215	380	205	250	13	1"
ND112M	190	140	70	112	36	222	50	170	12	28	60	44	8	24	31	7	4	M10 x 22	170	235	405	230	275	13	1"
ND132S ND132M	216	140 178	89	132	48	254	54	178 216	12	38	80	60	10	33	41	8	5	M12 x 28	190	275	470 510	270	320	16	1"

1. DIMENSIONS COMPLY WITH IS : 1231 AND ARE IN MM., EXCEPT CONDUIT ENTRY.
2. TERMINAL BOX CAN BE TURNED THROUGH 360° IN STEP OF 90°
3. CABLE ENTRY : 1 No. FOR DOL STARTING & TWO Nos. FOR STAR DELTA STARTING/MULTISPEED MOTOR
4. TERMINAL BOX ON LEFT HAND SIDE LOOKING FROM DRIVING END CAN BE PROVIDED WHEN SPECIFIED.
5. ALL DIMENSIONS ARE SUBJECTED TO CONFIRMATION.

ND9050

OUTLINE DIMENSION DRAWING FOR 3 PHASE SQUIRREL CAGE TEFC FLANGE MOUNTED CAST IRON BODY INDUCTION MOTORS FOR ND90 TO ND132 FRAMES

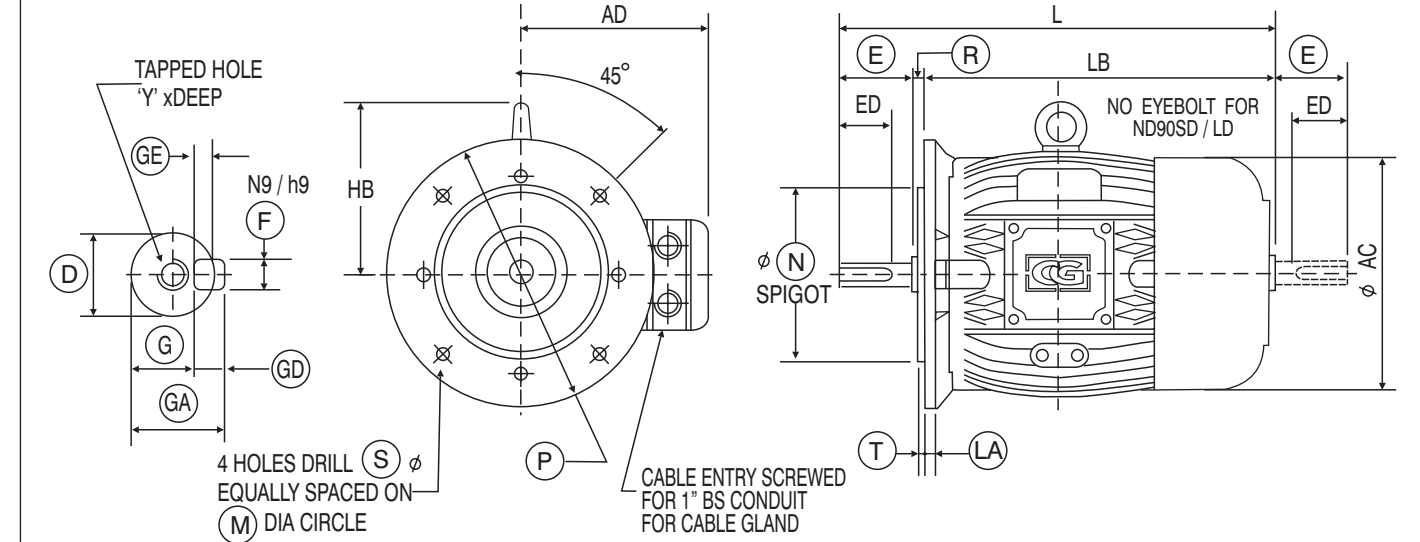

KEY		KEY WAY		SHAFT				FIXING	
GD	F	ED	F	GE	D		N	M	DN
h11	h9	-	N9	-	k6	j6	j6	-	GR.
6 to 10	3 to 6	30 to 80	4 to 6	4 & above	30 to 50	18 to 30	180 to 250	upto 265	RANGE
-0.090	-0.030	+0.300	+0.030	+0.200	+0.018	+0.009	+0.016	+0.300	TOL.

FRAME SIZE	FLANGE FIXING								SHAFT AND KEY								OVERALL(MAX)					
	M	N	P	R	S	T	LA	LB	D	E	ED	F	G	GA	GD	GE	YxDEEP	AD	AC	L	LB	HB
ND90SD ND90LD	165	130	200	0	12	3.5	10	24	50	36	8	20	27	7	4	M8x19	150	190	335 360	285 310	-	-
ND100LD	215	180	250	0	15	4	11	28	60	44	8	24	31	7	4	M10x22	160	210	380	310 320	150	
ND112MD	215	180	250	0	15	4	11	28	60	44	8	24	31	7	4	M10x22	170	230	405	330 345	160	
ND132SD ND132MD	265	230	300	0	15	4	14	38	80	60	10	33	41	8	5	M12x28	190	270	470 510	390 430	190	

1. DIMENSIONS COMPLY WITH IS : 1231 AND ARE IN MM., EXCEPT CONDUIT ENTRY.
2. TERMINAL BOX CAN BE TURNED THROUGH 360° IN STEP OF 90°
3. CABLE ENTRY : 1 No. FOR DOL STARTING & TWO Nos. FOR STAR DELTA STARTING/MULTISPEED MOTOR
4. TERMINAL BOX ON LEFT HAND SIDE LOOKING FROM DRIVING END CAN BE PROVIDED WHEN SPECIFIED.
5. ALL DIMENSIONS ARE SUBJECTED TO CONFIRMATION.

ND9040

OUTLINE DIMENSION DRAWING FOR 3 PHASE SQUIRREL CAGE TEFC FOOT MOUNTED INDUCTION MOTORS FOR ND160 TO ND355 FRAMES

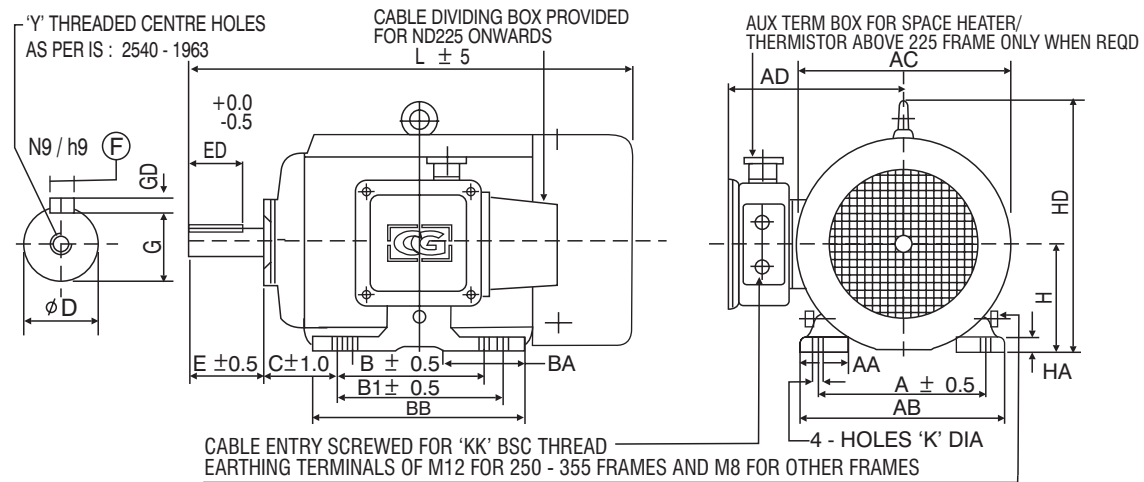

NOTE: CABLE ENTRY CAN BE TURNED TO ANY ONE OF THREE POSITIONS AT 90° INTERVALS. ALL DIMENSIONS ARE IN mm

FRAME SIZE	FOOT FIXING					SHAFT AND KEY#										OVERALL								
	A	B	B1	C	H TOL	AA	AB	BA	BB	KTOL	D TOL	E	ED	F TOL	GDTOL	G	Y	AD	AD1	AC	L	LB	HB	KK
ND 160 M	254	210	-	108	160.0	73	308	76	254	15.5	42.018	110	80	12.00	8.00	37.0	M16x32	275	318	605	376	22	432	2Nos-1"
ND 160 L		254	-		159.7				298	15.0	42.002			11.957	7.91	36.8								
ND 180 M	279	241	-	121	180.0	84	348	95	286	15.5	48.018	110	80	14.00	9.00	42.5	M16x32	295	352	677	418	22	476	2Nos-1.5"
ND 180 L		279	-		179.7				323	15.0	48.002			13.957	8.91	42.3								
ND 200 L	318	305	-	133	200.0	66	381	115	356	19.5	55.030	110	80	16.00	10.00	49.0	M20x40	345	428	805	480	25	528	2Nos-1.5"
ND 225S	356	286	-	149	225.0	70	425	102	375	19.5	60.030	140	110	18.00	11.00	53.0								
ND 225M		-	311		-					224.5	19.5			60.011	17.957	10.91	52.8	375	470	880	534	25		
ND 250S	406	311	-	168	250.0	80	483	135	419	24.5	65.030	140	110	18.00	11.00	58.0	M20x40	405	500	940	598	32	688	2Nos-1.5"
ND 250M		-	349		-					249.5	24.0			65.011	17.957	10.91								
ND 280S	457	368	-	190	280.0	100	538	167	487	24.5	75.030	140	110	20.00	12.00	67.5	M20x40	430	536	1085	642	35	724	2Nos-2"
ND 280M		-	419		-					279.0	24.0			75.011	19.948	11.91								
ND 315S	508	406	-	216	315.0	110	597	164	533	28.5	80.030	170	140	22.00	14.00	71.00	M24x50	510	588	1230	725	38	820	2Nos-2"
ND 315M		-	457		-					314.0	28.0			80.011	21.948	13.91								
ND 315L	508	508	-	216	315.0	110	610	230	740	28.5	90.035	170	140	25.00	14.00	81.0	M24x50	570	655	1375	755	35	820	2Nos-2.5"
ND 355S	-	500	-	314.0	28.0	90.013	24.948	13.91	80.8	570	655	1375	755	35										
ND 355M	610	-	560	254	355.0	110	710	253	745	28.5	100.035	210	160	28.000	16.00	90.0	M24x50	560	672	1513	760	40	890	2Nos-2.5"
ND 355L		-	-		-					354.0	28.0			100.013	27.948	15.89								
ND 355LX	630	-	-	-	-	-	-	250	880	-	-	-	-	-	-	-	600	720	1570	827	-	-	-	

#	FRAME SIZE	D TOL	E	ED	F TOL	GD TOL	G	L			
								S	M	L	LX
ABOVE 200 FRAME MACHINES RUNNING AT 3000 SYN RPM HAVE SMALLER SHAFTS AS SHOWN HERE	ND 225	55.030/55.011	110	80	16.0/15.957	10.0/9.91	49.0/48.8	850	850	-	-
	ND 250	60.030/60.011	140	110	18.0/17.957	11.0/10.91	53.0/52.8	940	940	-	-
	ND 280	65.030/65.011	140	110	18.0/17.957	11.0/10.91	58.0/57.8	1085	1085	-	-
	ND 315							1200	1200	-	-
	ND 315	70.030/70.011	140	110	20.0/19.948	12.0/11.91	62.5/62.3	-	-	1345	-
ND 355	75.030/75.011	170	140	20.0/19.948	12.0/11.91	67.5/67.3	1473	1473	1473	1530	

ND16050

OUTLINE DIMENSION DRAWING FOR 3 PHASE SQUIRREL CAGE TEFC FLANGE MOUNTED INDUCTION MOTORS FOR ND160 TO ND355 FRAMES

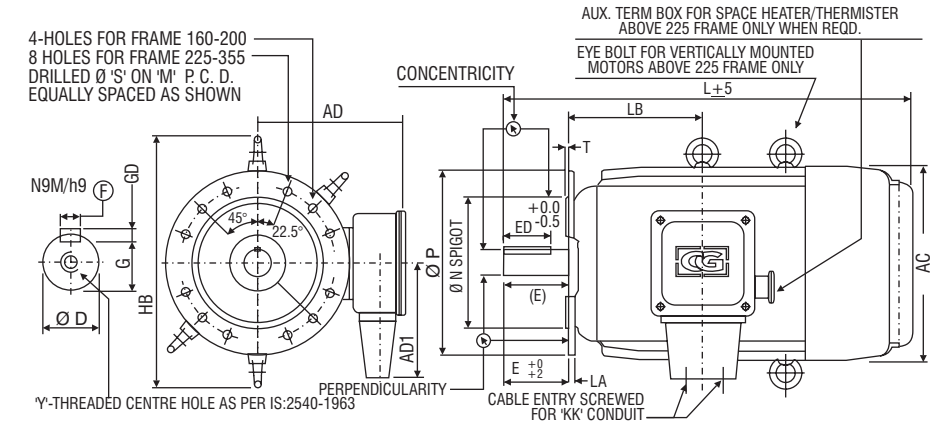

ALL DIMENSIONS ARE IN mm

NOTE:- CABLE ENTRY CAN BE TURNED TO ANY ONE OF THREE POSITIONS AT 90° INTERVALS

FRAME SIZE	FLANGE FIXING					SHAFT AND KEY#										OVERALL							
	M TOL	N TOL	P	S	T	LA	D TOL	E	ED	F TOL	GD TOL	G	Y	AD	AD1	AC	L	LB	HB	KK			
ND160M	300.5	250.016	350	19	5	18	42.018	110	80	11.957	7.91	36.8	M11x32	275	152	318	660	213	432	2Nos-1"			
ND160L							42.002														705	235	
ND180M	299.5	249.957	400	19	5	18	48.018	110	80	14.00	9.00	42.5	M11x32	295	152	352	746	241.5	476	2Nos-1"			
ND180L							48.002														784	260.5	
ND 200L	350.5	300.018	450	19	5	15	55.030	110	80	16..	10.00	49.0	M20x40	345	282	428	873	285.5	528	2Nos-1.5"			
ND 225S	349.5	299.982					55.011														15.957	9.91	48.8
ND 225M	400.5	350.018	550	19	5	19	60.030	140	110	18.00	11.00	53.0	M20x40	375	282	470	955	3.4.5	590	2Nos-1.5"			
ND 250S	399.5	349.982					60.011														17.957	10.91	52.8
ND 250M	500.5	450.020	660	24	6	25	65.030	140	110	18.00	11.00	58.0	M24x50	405	420	500	1020	342.5	688	2Nos-1.5"			
ND 280S	499.5	449.980					65.011														17.957	10.91	57.8
ND 280M	500.5	450.020	800	24	6	28	75.030	140	110	20.00	12.00	67.5	M24x50	430	420	536	1170	399.5	724	2Nos-1.5"			
ND 315S	499.5	449.980					75.011														19.948	11.91	67.3
ND 315L	601.0	550.022	800	24	6	25	80.030	170	140	22.00	14.00	71.0	M24x50	510	420	588	1340	444.5	820	2Nos-2"			
ND 315M	599.0	549.978					80.011														21.948	13.91	70.8
ND 355S	601.0	550.022	800	24	6	28	90.035	170	140	25.00	14.00	81.0	M24x50	570	420	655	1490	530.5	820	2Nos-2.5"			
ND 355L	599.0	549.978					90.013														24.948	13.91	80.8
ND 355LX	741.0	680.025	800	24	6	28	100.035	210	160	28.000	16.00	90.0	M24x50	600	420	670	1513	570	890	2Nos-2.5"			
ND 355LX	739.0	679.975					100.013														27.948	15.89	89.9

#	FRAME SIZE	D TOL	E	ED	F TOL	GD TOL	G	L			
								S	M	L	LX
ABOVE 200 FRAMES MACHINES RUNNING AT 3000 SYN.RPM HAVE SMALLER SHAFTS AS SHOWN HERE	ND 225	55.030/55.011	110	80	16.0/15.957	10.0/9.91	49.0/48.8	925	925	-	-
	ND 250	60.030/60.011	140	110	18.0/17.957	11.0/10.91	53.0/52.8	1020	1020	-	-
	ND 280	65.030/65.011	140	110	18.0/17.957	11.0/10.91	58.0/57.8	1170	1170	-	-
	ND 315							1310	1310	-	-
	ND 315	70.030/70.011	140	110	20.0/19.948	12.0/11.91	62.5/62.3	-	-	1460	-
ND 355	75.030/75.011	170	140	20.0/19.948	12.0/11.91	67.5/67.3	1473	1473	1473	1530	

FRAME SIZE	CONCENTRICITY IN MICRON		PERPENDICULARITY IN MICRON		RUNOUT IN MICRON	
	NORM. CLASS		NORM. CLASS		SHAFT Ø	NORM.
160-280	125		125		30-50	50
315-355					50-80	60
			160		80-120	70

ND16040

OUTLINE DIMENSION DRAWING FOR 3 PHASE SQUIRREL CAGE TEFC FOOT CUM FLANGE MOUNTED INDUCTION MOTORS FOR ND160 TO ND355 FRAMES

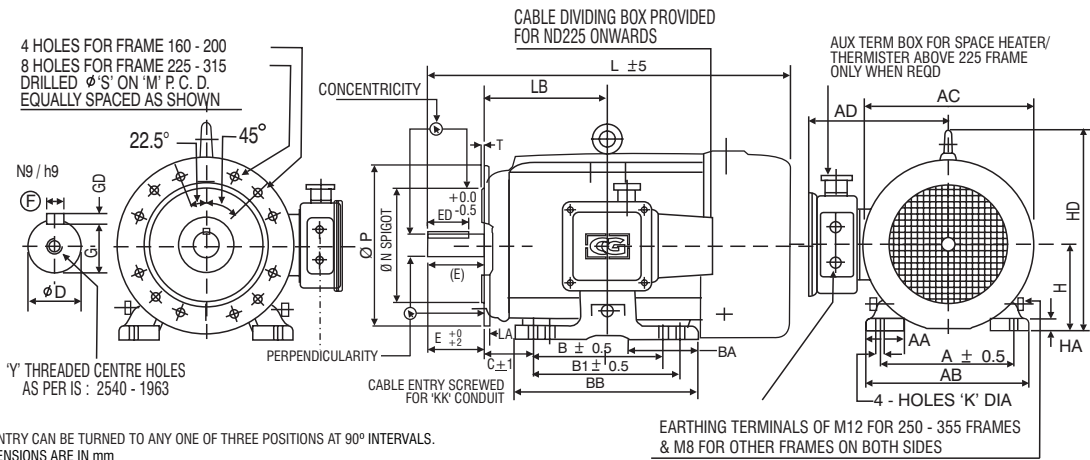

FRAME SIZE	FOOT FIXING										FLANGE FIXING				SHAFT AND KEY#									
	A	B	B1	C	H TOL.	AA	AB	BA	BB	K TOL.	M TOL.	N TOL.	P	S	LA	T	D TOL.	E	ED	F TOL.	GD TOL.	G	Y	
ND160M	254	210	-	108	160.0	73	308	76	254	15.5	300.5	250.016					42.018	110	80	12.00	8.00	37.0	M16x32	
ND 160L		254	-		159.7				298	15.0							42.002			11.957	7.91	36.8		
ND 180M	279	241	-	121	180	84	348	95	286	15.5	299.5	249.987	350	19	18	5	48.018	110	80	14.00	9.00	42.5		
ND 180L			279	-		179.7				323	15.0							48.002			13.957	8.91		42.3
ND 200L	318	305	-	133	200.0	66	381	104	356	19.5	350.5	300.018	400	19	18	5	55.030	110	80	16.00	10.00	49.0	M20x40	
ND 225S	356	286	-	149	225.0	70	425	102	375	19.5	400.5	350.018	450	19	19	5	50.030	140	110	18.00	11.00	53.0		
ND 225M			-	311	224.5						19.0	399.5	349.982					50.011			17.957	10.91		52.8
ND 250S	406	311	-	168	250.0	80	483	135	419	24.5	500.5	450.020	550	19	22	5	65.030	140	110	18.00	11.00	58.0		
ND 250M			-	349	249.5						24.0	499.5	449.980					65.011			17.957	10.91	57.8	
ND280S	457	368	-	190	280.0	100	538	198	487	24.5	599.5	549.980	660	24	25	6	75.030	140	110	20.00	12.00	67.5	M24x50	
ND 280M			-	419	279.0						24.0	599.0	549.978					75.011			19.948	11.91		67.3
ND 315S	508	406	-	216	315.0	110	597	164	533	28.5	601.0	550.022	660	24	25	6	80.030	170	140	22.00	14.00	71.0		
ND 315M			-	457	314.0						28.0	599.0	549.978					80.011			21.948	13.91		70.8
ND 315L	508	508	-	216	315.0	110	610	230	740	28.5	599.0	549.978	660	24	25	6	90.035	170	140	25.00	14.00	81.00		
ND 355S	610	500	-	254	355.0	110	710	253	745	28.5	741.0	680.025	800	24	28	6	100.035	210	160	28.000	16.00	90.0		
ND 355M			-	560	354.0						28.0	739.0	679.975					100.013			27.948	15.89	89.8	
ND 355L			-																					
ND 355LX			630	-					250	880														

FRAME SIZE	OVERALL							
	AD	AC	L	LB	HD	HA	KK	
ND160M	275	318	605	213	376	22		2 Nos-1"
ND160L			650	235				
ND180M	295	352	677	241.5	418	22		
ND180L				715	260.5			
ND200L	345	428	805	285.5	480	25		2 Nos-1.5"
ND225S	375	470	880	304.5	534	25		
ND 225M								
ND250S	405	500	940	342.5	598	32		
ND 250M								
ND280S	430	536	1085	399.5	642	35		
ND280M								
ND315S	510	588	1230	444.5	725	38		
ND315M								
ND315L	570	655	1375	530.5	755	35		2 Nos-2.5"
ND355 S/M/L	560	672	1513	570	760	40		
ND355LX	600	720	1570	591	827			

FRAME SIZE	D TOL	E	ED	F TOL	GD TOL	G	L
ND225M	55.011	110	80	15.957	9.91	48.8	850
ND250S	60.030	140	110	18.00	11.00	53.0	940
ND250M	60.011			17.957	10.91	52.8	940
ND280S	65.030	140	110	18.00	11.00	58.0	1085
ND280M	65.011			17.957	10.91	57.8	
ND315S	65.030	140	110	18.00	11.00	58.0	1200
ND315M	65.011			17.957	10.91	57.8	1200
ND315L	70.030	140	110	20.00	12.00	62.5	1345
ND355 S/M/L	75.030	170	140	20.00	12.00	67.5	1473
ND355LX	75.011			19.948	11.91	67.3	1530

ABOVE 200 FRAMES MACHINES RUNNING AT 3000 SYN. RPM HAVE SMALLER SHAFTS AS SHOWN HERE

FRAME SIZE	CONCENTRICITY IN MICRON	PERPENDICULARITY MICRON	RUNOUT IN MICRON
	NORM.	NORM.	SHAFT φ
160-280	63	125	30-50
			50-80
315-355	160	150	80-120
			70

ND16060

OUTLINE DIMENSION DRAWING FOR 3 PHASE SQUIRREL CAGE SPDP FOOT MOUNTED INDUCTION MOTORS FOR C160 TO C200 FRAMES

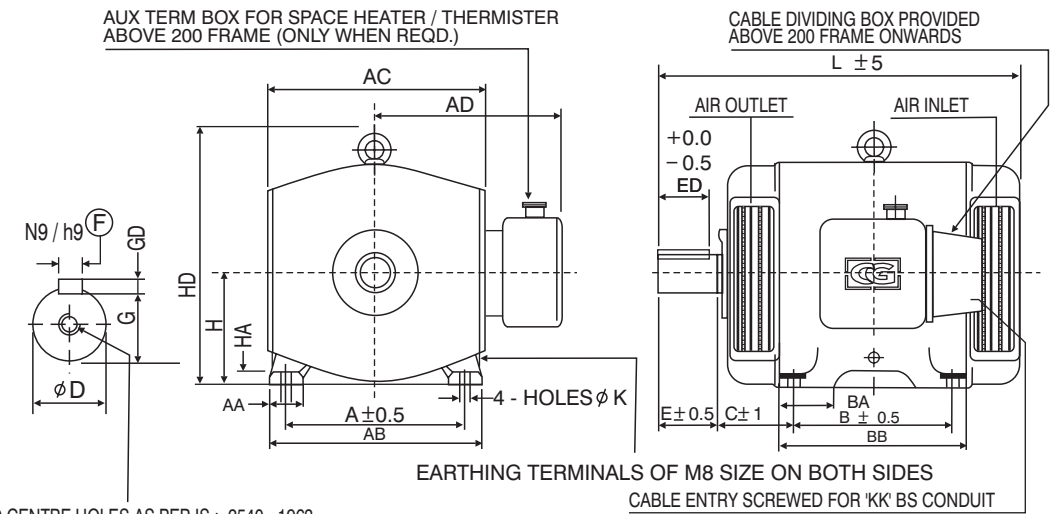

FRAME SIZE	FOOT FIXING										SHAFT AND KEY						OVERALL					
	A	B	C	H TOL.	AA	AB	BA	BB	K TOL	D TOL	E	ED	F TOL	GD TOL	G	Y	AD	AC	L	HD	HA	KK
C 160M	254	210	108	160.0	54	298	76	254	15.5	48.002	110	80	14.0	9.00	42.5	M16x32	290	390	536	395	22	2Nos-1"
C 160L			254		159.7				298										15.0			
C 180M	279	241	121	180.0	60	337	95	285	15.5	55.030	110	80	16.0	10.00	49.0		335	420	593	445	22	
C 180L			279		179.7				323										15.0			
C 200M	318	267	133	200.0	65	381	105	318	19.5	60.030	140	110	18.0	11.00	53.0	M20x40	398	460	673	498	25	2Nos-1.5"
C 200L			305		199.5				355										19.0			

AC16050

OUTLINE DIMENSION DRAWING FOR 3 PHASE SQUIRREL CAGE SPDP FOOT MOUNTED INDUCTION MOTORS FOR C225 TO C315 FRAMES

AUX TERM BOX FOR SPACE HEATER / THERMISTER ONLY WHEN REQD.

CABLE DIVIDING BOX PROVIDED ABOVE 200 FRAME ONWARDS

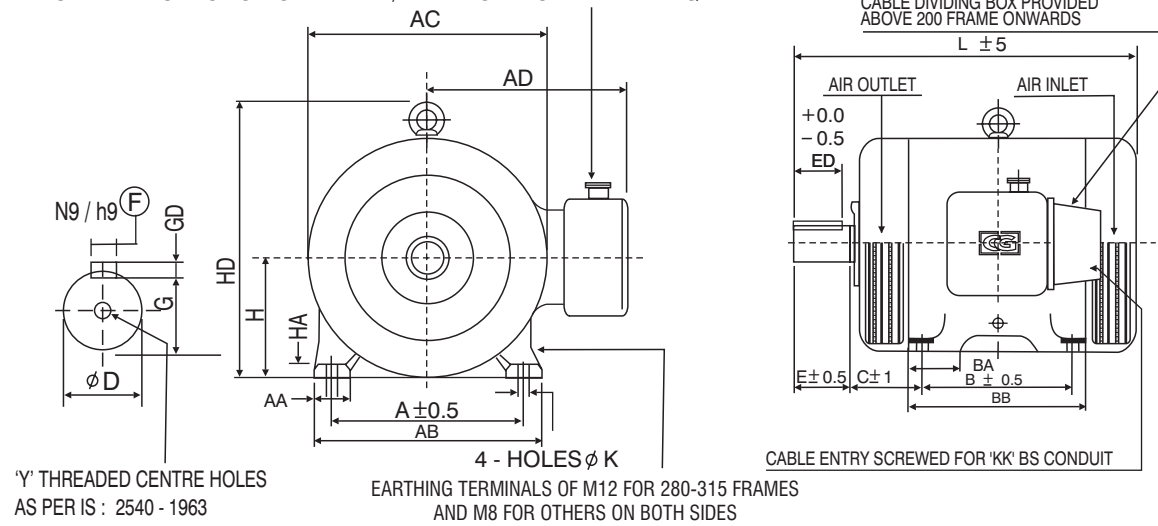

CABLE ENTRY CAN BE TURNED TO ANY ONE OF TWO POSITIONS AT 90° INTERVALS.

ALL DIMENSIONS ARE IN mm

OUTLINE DIMENSION DRAWING FOR 3 PHASE SQUIRREL CAGE SPDP FLANGE MOUNTED INDUCTION MOTORS FOR C160 TO C200 FRAMES

AUX TERM BOX FOR SPACE HEATER/ THERMISTER ABOVE 200 FRAME ONLY WHEN REQD.

4-HOLES FOR FRAMES 160-180
8-HOLES FOR FRAMES 200
DRILL ϕ 'S' ON 'M' P.C.D.
EQ.SP AS SHOWN

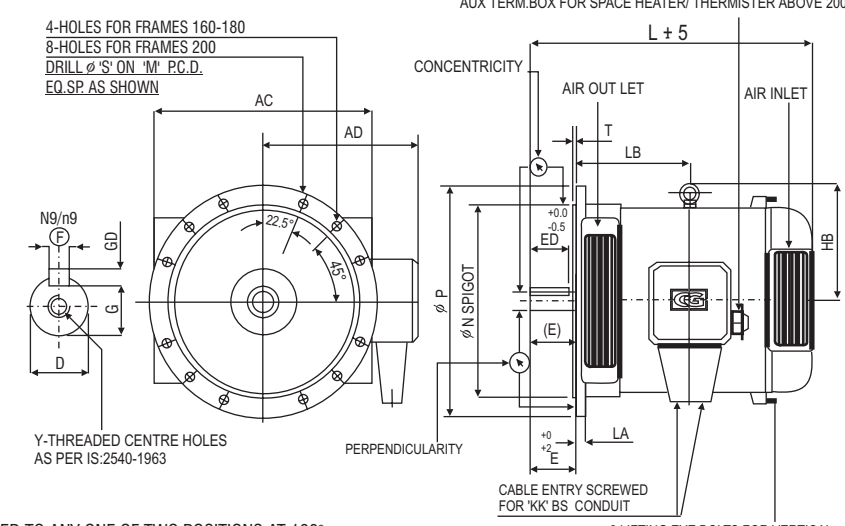

NOTE:-
CABLE ENTRY CAN BE TURNED TO ANY ONE OF TWO POSITIONS AT 180° INTERVALS EXCEPT FROM NON DRIVING END.

ALL DIMENSIONS ARE IN mm

FRAME SIZE	FOOT FIXING									SHAFT AND KEY#						OVERALL							
	A	B	C	H TOL.	AA	AB	BA	BB	K TOL	D TOL	E	ED	F TOL	GD TOL	G	Y	AD	AC	L	HD	HA	KK	
C225M	356	311	149	225.0 224.5	70	426	125	427	19.5 19.0	65.030 65.011	140	110	18.000 17.957	11.00 10.91	58.0 57.8	M20x40	398	450	800	520	25	2Nos-1.5"	
C 250S	405	311	168	250.0 249.5	80	483	127	381	24.5	75.030	140	110	20.000	12.00	67.5		428	500	787	605	28		
C 250M		349	168	249.5			127	419	24.0	75.011			19.948	11.91	67.3		927						
C 250MX																							
C 280S	457	368		280.0	83	540	146	438	24.5	80.030	170	140	22.000	14.00	71.0		515	560	918	663	35		
C 280M		419	190	279.0			489	24.0	80.011	21.948			13.91	70.8	969								
C 280MX																							
C315S	508	406	216	315.0	89	597	153	482	28.5	90.035	170	140	25.000	14.00	81.0		555	630	1008	734	38		
C 315M		457	216	314.0			533	28.0	90.013	24.948			13.91	80.8	1059								
C 315MX																							

# ABOVE 200 FRAMES MACHINES RUNNING AT 3000 SYN. RPM HAVE SMALLER SHAFTS AS SHOWN HERE	FRAME	D TOL	E	ED	F TOL	GD TOL	G	L		
								S	M	MX
	C225	60.030/60.011	140	110	18.0/17.957	11.0/10.91	53.0/52.8	-	800	-
	C250	65.030/65.011	140	110	18.0/17.957	11.0/10.91	58.0/57.8	787	927	927
	C280	65.030/65.011	140	110	18.0/17.957	11.0/10.91	58.0/57.8	888	939	1041
	C315	70.030/70.011	140	110	20.0/19.948	12.0/11.91	62.5/62.3	978	1029	1156

AC22550

FRAME SIZE	FLANGE FIXING						SHAFT AND KEY						OVERALL						
	M TOL	N TOL	P	S	T	LA	D TOL	E	ED	F TOL	GD TOL	G	Y	AD	AC	L	LB	HB	KK
C160M							48.018 48.002	110	80	14.00 13.957	9.00 8.91	42.5 42.3	M16x32	290	325	536	213	235	2Nos-1"
C160L	350.5 349.5	300.016 299.984	400	19	5	19													
C180M							55.030 55.011	110	80	16.00 15.957	10.00 9.91	49.0 48.8	M20x40	235	352	593	241.5	265	2Nos-1.5"
C 180I																			
C 200M	400.5	350.018	450	19	5	19	60.030	140	110	18.00	11.00	53.0	M20x40	398	450	673	266.5	298	2Nos-1.5"
C 200L	399.5	349.982					60.011			17.957	10.91	52.8							

FRAME SIZE	CONCENTRICITY IN MICRON	PERPENDICULARITY IN MICRON	RUNOUT IN MICRON	
	NORM. CLASS	NORM. CLASS	SHAFT ϕ	NORM.
160-200	125	125	30-50	50

AC16040

OUTLINE DIMENSION DRAWING FOR 3 PHASE SQUIRREL CAGE SPDP FLANGE MOUNTED INDUCTION MOTORS FOR C225 TO C315 FRAMES

8 - HOLES FOR FRAMES 225 - 315
DRILL ϕ 'S' ON 'M' P. C. D.
EQ. SP. AS SHOWN

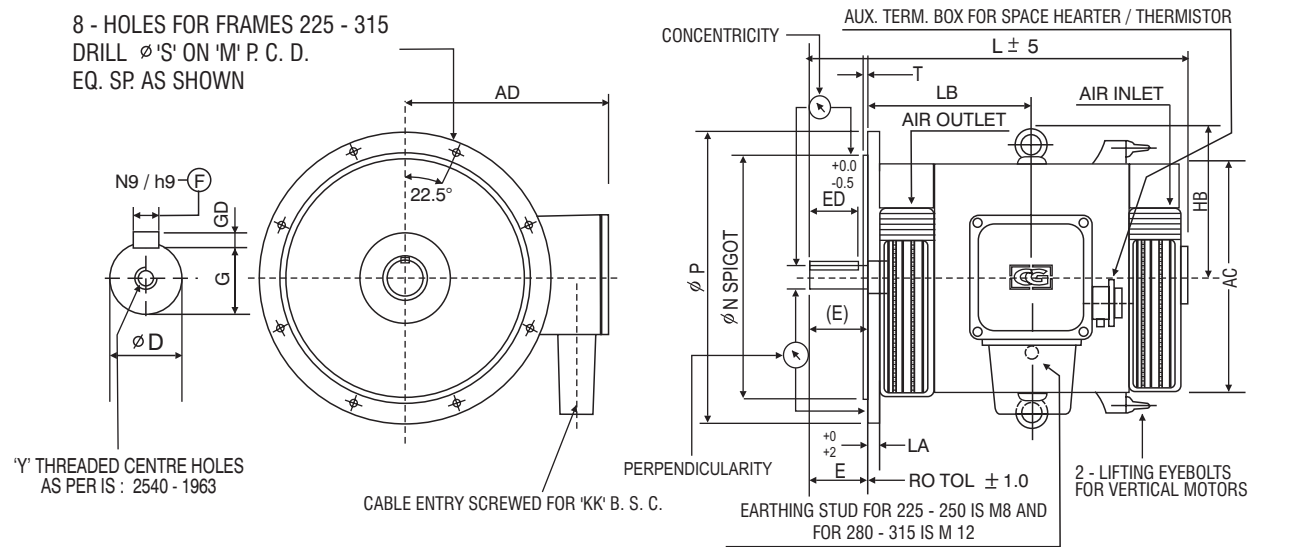

NOTE:-
CABLE ENTRY CAN BE TURNED TO ANY ONE OF TWO POSITIONS AT 90° INTERVALS.

ALL DIMENSIONS ARE IN mm

FRAME SIZE	FLANGE FIXING						SHAFT AND KEY#							OVERALL						
	M TOL	N TOL	P	S	T	LA	D TOL	E	ED	F TOL	GD TOL	G	Y	AD	AC	L	LB	HB	KK	
C 225M	500.5	450.020	550	19	5	25	65.030	140	110	18.00	11.00	58.0		398	450	800	304.5	295	2Nos-2"	
	499.5	449.980					65.011			17.957	10.91	57.8								
C250M	601.0	550.022					75.030	140	110	20.00	12.00	67.5		428	500	825	342.5	355		
C250MX	599.0	549.978	660	24	6	25	75.011			19.948	11.91	67.3				927				
C280M	601.0	550.022					80.030	170	140	22.00	14.00	71.0		515	560	969	399.5	383		
C280MX	599.0	549.978	660	24	6	25	80.011	170	140	21.948	13.91	70.8				1071				
C315M	741.0	680.025					90.035	170	140	25.00	14.00	81.0		555	630	1059	444.5	419		
C315MX	739.0	679.975	800	24	6	28	90.013			24.948	13.91	80.8		576		1186				

# MACHINES RUNNING AT 3000 SYN. RPM HAVE SMALLER SHAFTS AS SHOWN HERE	FRAME SIZE	D TOL	E	ED	F TOL	GD TOL	G	L	
								M	MX
	C 225	60.030/60.011	140	110	18.0/17.957	11.0/10.91	53.0/52.8	800	-
	C 250	65.030/65.011	140	110	18.0/17.957	11.0/10.91	58.0/57.8	825	927
	C280	65.030/65.011	140	110	18.0/17.957	11.0/10.91	58.0/57.8	939	1041
C315	70.030/70.011	140	110	20.0/19.948	12.0/11.91	62.5/62.3	1029	1156	

FRAME SIZE	CONCENTRICITY IN MICRON	PERPENDICULARITY IN MICRON	RUNOUT IN MICRON	
	NORM. CLASS	NORM. CLASS	SHAFT ϕ	NORM.
225-315	125	125	50-80	60

AC22540

OUTLINE DIMENSION DRAWING FOR 3 PHASE SLIP RING TEFC FOOT MOUNTED INDUCTION MOTORS FOR DW132S/M

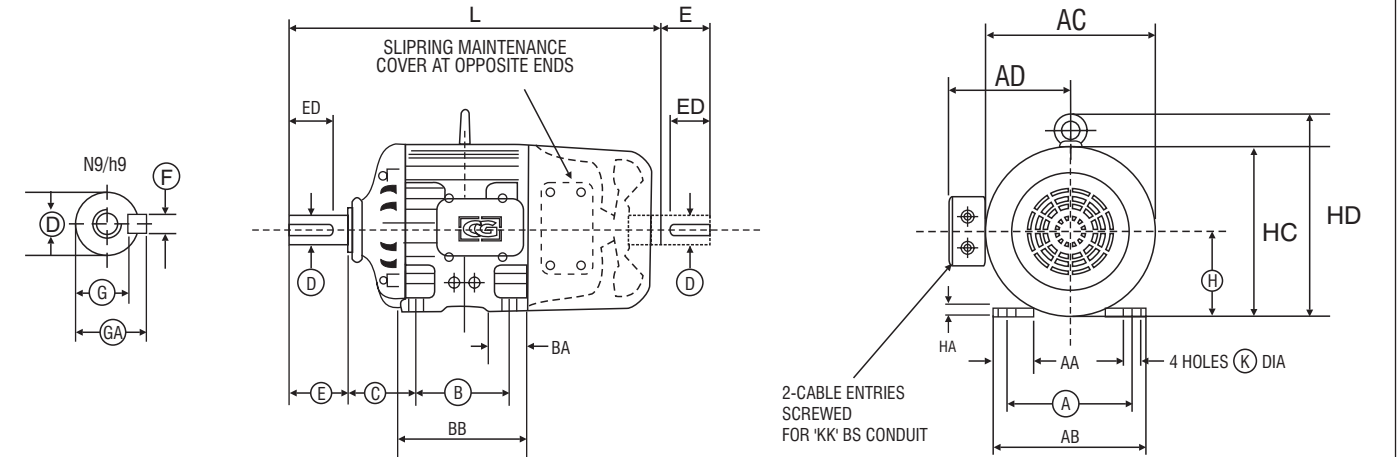

ALL DIMENSIONS ARE IN mm

FRAME SIZE	FOOT FIXING					SHAFT AND KEY										OVERALL (max)								
	A	B	C	H	AA	AB	BA	BB	K	D	TOL	E	ED	F	G	GA	AD	AC	L	HC	HD	HA	KK	
DW 132S	165	140	89	-	132	41	254	64	178	12	38	+0.018	80	60	10	33.0	41	225	320	600	290	350	16	1"
DW 132 M		178							216			-0.002				32.8			640					B.S.C.

- NOTES: 1 DIMENSIONS COMPLY WITH IS:1231 & ALL DIMENSIONS IN MILLIMETRE EXCEPT CONDUIT ENTRY.
2 CABLE ENTRIES CAN BE TURNED THROUGH 360° IN STEP 90°
3 TERMINAL BOX ON LEFT HAND SIDE LOOKING FROM DRIVING END CAN BE PROVIDED WHEN SPECIFIED

DW13250

OUTLINE DIMENSION DRAWING FOR 3 PHASE SLIP RING TEFC FLANGE MOUNTED INDUCTION MOTORS FOR DW132S/M

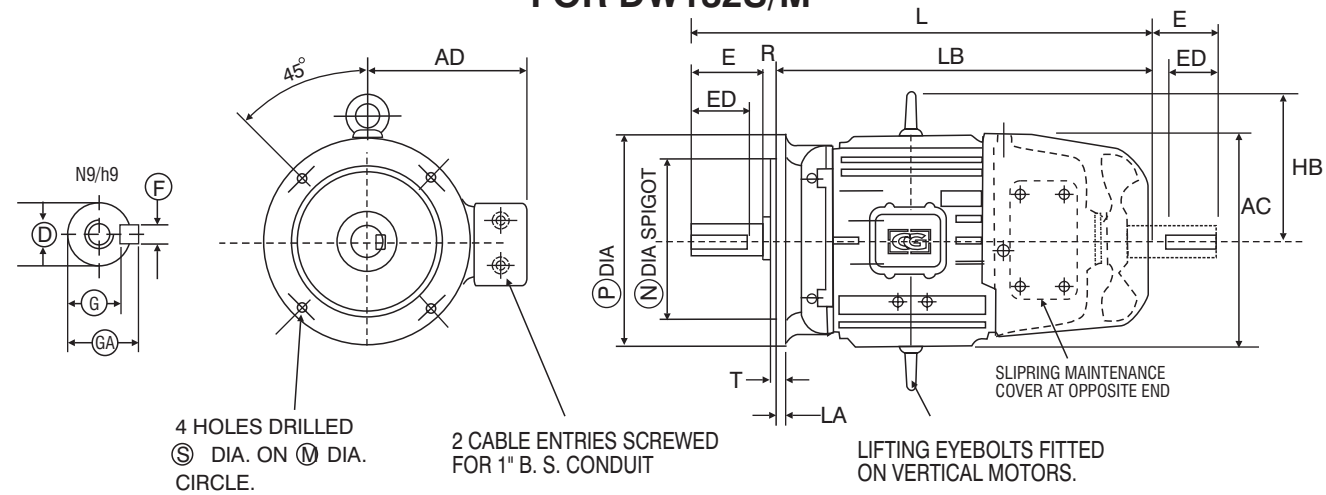

ALL DIMENSIONS ARE IN mm

FRAME SIZE	FLANGE FIXING							SHAFT AND KEY							OVERALL (max)				
	M	N	P	R	S	T	LA	D	E	ED	F	G	GA	AD	L	LB	AC	HB	
DW 132SD	300	230	350	0	15	4	13	38	80	56	10	33.0	41	255	600	520	320	215	
DW 132MD												32.8			640	560			

- NOTES: 1 THE CABLE ENTRY CAN BE TO ANY ONE OF FOUR POSITIONS AT 90° INTERVAL
 2 COMPRESSION GLAND FITTED WHEN REQUIRED

DW13240

OUTLINE DIMENSION DRAWING FOR 3 PHASE SLIP RING TEFC FOOT MOUNTED INDUCTION MOTORS FOR NDW160 TO NDW355 FRAMES

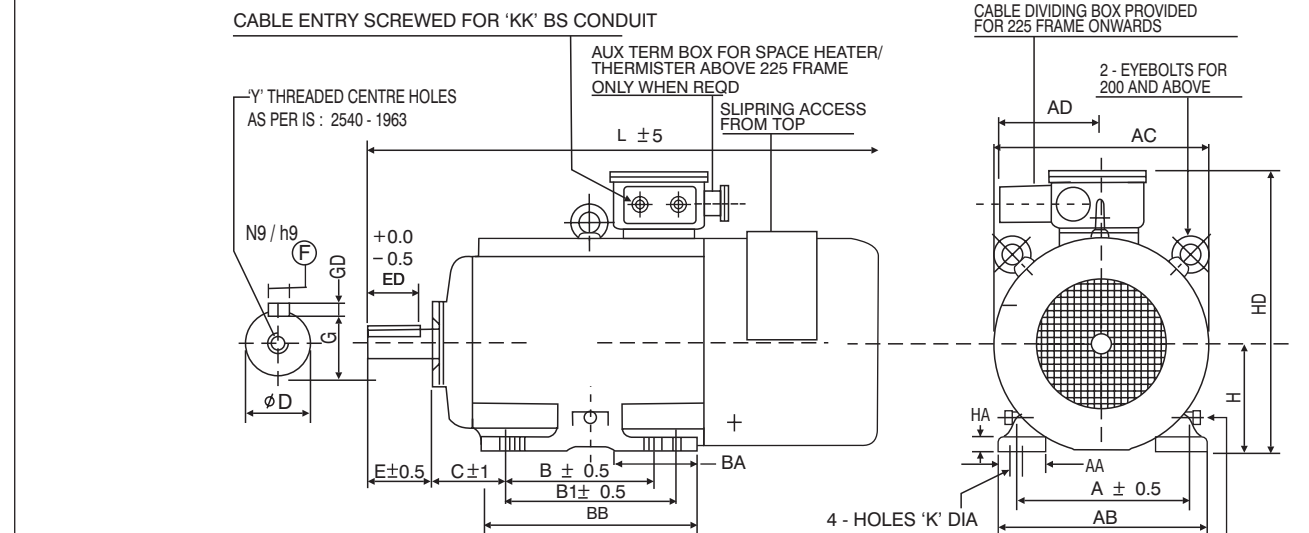

NOTE:-
 CABLE ENTRY CAN BE TURNED TO ANY ONE OF TWO POSITIONS AT 90° INTERVALS.

ALL DIMENSIONS ARE IN mm

FRAME SIZE	FOOT FIXING										SHAFT AND KEY						OVERALL						
	A	B	B1	C	H TOL	AA	AB	BA	BB	KTOL	D TOL	E	ED	F TOL	GDTOL	G	Y	AD	AC	L	HD	HA	KK
NDW160 M	254	210	-	108	160.0	73	308	76	254	15.5	42.018	110	80	12.00	8.00	37.0	M16x32	-	318	766	435	22	2Nos-1"
NDW160 L		254	-		159.7				298	15.0	42.002			11.957	7.91	36.8				810			
NDW180 M	279	241	-	121	180.0	84	348	95	286	15.5	48.018	110	80	14.00	9.00	42.5	M16x32	-	352	840	475	22	2Nos-1"
NDW180 L		279	-		179.7				323	15.0	48.002			13.957	8.91	42.3				878			
NDW 200 L	318	305	-	133	200.0 199.5	66	381	115	356	19.5 19.0	55.030 55.011	110	80	16.00 15.957	10.00 9.91	49.0 48.8	M20x40	285	428	952	545	25	2Nos-1.5"
NDW225S	356	286	-	149	225.0	70	425	102	375	19.5	60.030	140	110	18.00	11.00	53.0				1072	600	25	
NDW225M		-	311		224.5					19.0	60.011			17.957	10.91	52.8							
NDW250S	406	311	-	168	250.0	80	483	135	419	24.5	65.030	140	110	18.00	11.00	58.0	M20x40	285	500	1128	730	32	2Nos-1.5"
NDW250M		-	349		249.5					24.0	65.011			17.957	10.91	57.8							
NDW280S	457	368	-	190	280.0	100	538	167	487	24.5	75.030	140	110	20.00	12.00	67.5	M20x40	285	536	1265	810	35	2Nos-1.5"
NDW280M		-	419		279.0					24.0	75.011			19.948	11.91	67.3							
NDW315S	508	406	-	216	315.0	110	597	164	533	28.5	80.030	170	140	22.00	14.00	71.00	M24x50	375	588	1460	845	38	2Nos-2"
NDW315M		-	457		314.0					28.0	80.011			21.948	13.91	70.8							
NDW315L	508	508	-	216	315.0 314.0	110	610	230	740	28.5 28.0	90.035 90.013	170	140	25.00 24.945	14.00 13.91	81.0 80.8	M24x50	420	655	1575	885	35	2Nos-2"
NDW355S		500																					
NDW355M	610	-	560	254	355.0 354.0	110	710	253	745	28.5 28.0	100.035 100.013	210	160	28.000 27.948	16.00 15.89	90.0 89.8	M24x50	560	672	1675	760	40	2Nos-2.5"
NDW355L		630	-																				
NDW355LX																							

NDW16050

OUTLINE DIMENSION DRAWING FOR 3 PHASE SLIP RING SPDP FOOT MOUNTED INDUCTION MOTORS FOR CW160 TO CW200 FRAMES

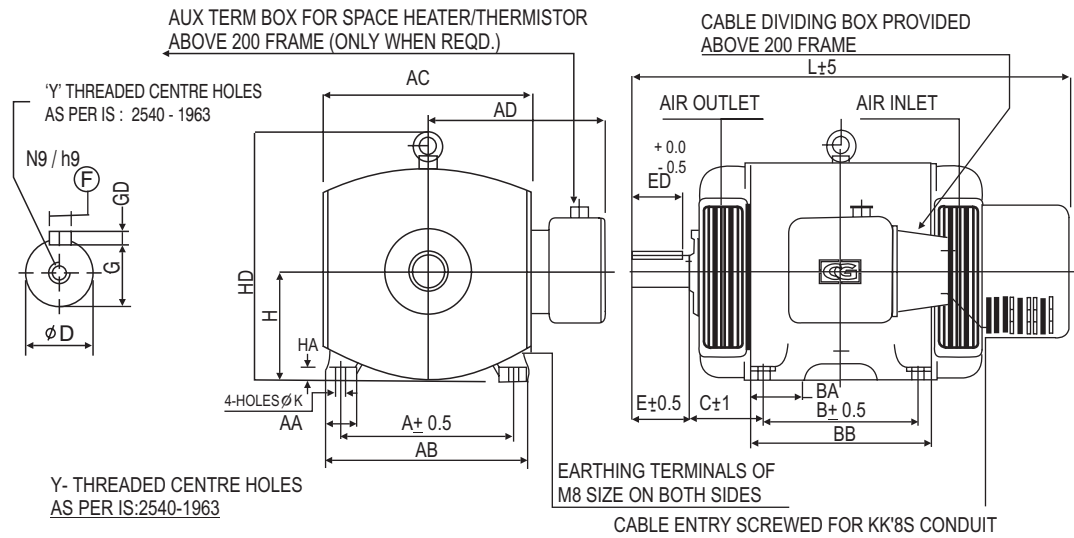

NOTE:-
CABLE ENTRY CAN BE TURNED TO ANY ONE OF TWO POSITIONS AT 90° INTERVALS

ALL DIMENSIONS ARE IN mm

OUTLINE DIMENSION DRAWING FOR 3 PHASE SLIP RING SPDP FOOT MOUNTED INDUCTION MOTORS FOR CW225 TO CW315 FRAMES

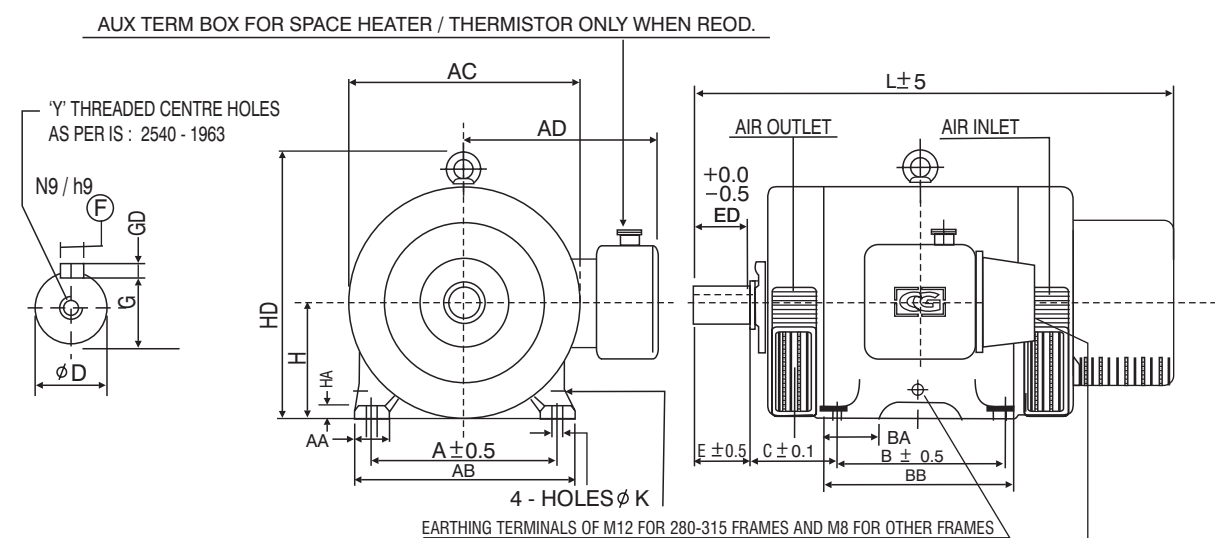

NOTE:-
CABLE ENTRY CAN BE TURNED TO ANY ONE OF TWO POSITIONS AT 90° INTERVALS.

ALL DIMENSIONS ARE IN mm

FRAME SIZE	FOOT FIXING									SHAFT AND KEY						OVERALL						
	A	B	C	H TOL.	AA	AB	BA	BB	K TOL.	D TOL.	E	ED	F TOL.	GD TOL.	G	Y	AD	AC	L	HD	HA	KK
CW160M	254	210	108	160.0	54	298	76	254	15.5	48.018	110	80	14.0	9.00	42.5	M16x32	290	390	680	395	22	2Nos-1"
CW160L		254		159.7				298	15.0	48.002			13.957	8.91	42.3				724			
CW180M	279	241	121	180.0	60	337	95	285	15.5	55.030	110	80	16.0	10.00	49.0	M20x40	335	420	802	445	22	2Nos-1.5"
CW180L		279		179.7				323	15.0	55.011			15.957	09.91	48.8				840			
CW200M	318	267	133	200.0	65	381	105	318	19.5	60.030	140	110	18.0	11.00	53.0	M20x40	398	460	877	498	25	2Nos-1.5"
CW200L		305		199.5				355	19.0	60.011			17.957	10.91	52.8				915			

FRAME SIZE	FOOT FIXING									SHAFT AND KEY						OVERALL						
	A	B	C	H TOL.	AA	AB	BA	BB	K TOL.	D TOL.	E	ED	F TOL.	GD TOL.	G	Y	AD	AC	L	HD	HA	KK
CW225M	356	311	149	225.0	70	426	125	427	19.5	65.030	140	110	18.000	11.00	58.0	M20x40	398	450	1000	520	25	2Nos-1.5"
CW250S				224.5				19.0	65.011	17.957			10.91	57.8	428				500			
CW250M	405	349	168	250.0	80	483	127	381	24.5	75.030	140	110	20.000	12.00	67.5	M20x40	428	500	987	605	28	2Nos-1.5"
CW250MX				249.5				24.0	75.011	19.948			11.91	67.3	1125							
CW280S	457	419	190	280.0	83	540	146	438	24.5	80.030	170	140	22.000	14.00	71.0	M20x40	515	560	1220	663	35	2Nos-2"
CW280M				279.0				24.0	80.011	21.948			13.91	70.8	1270							
CW280MX	508	406	216	315.0	89	597	153	482	28.5	90.035	170	140	25.000	14.00	81.0	M24x50	555	630	1300	734	38	2Nos-2"
CW315S				314.0				28.0	90.013	24.948			13.91	80.8	1350							
CW315M	508	457	216	314.0	89	597	153	533	28.0	90.013	170	140	24.948	13.91	80.8	M24x50	576	630	1475	734	38	2Nos-2"
CW315MX				1475																		

**CONNECTION DIAGRAM FOR
3PHASE INDUCTION MOTORS**

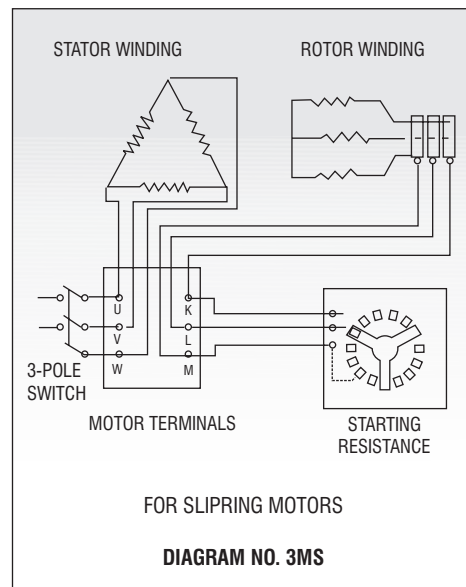
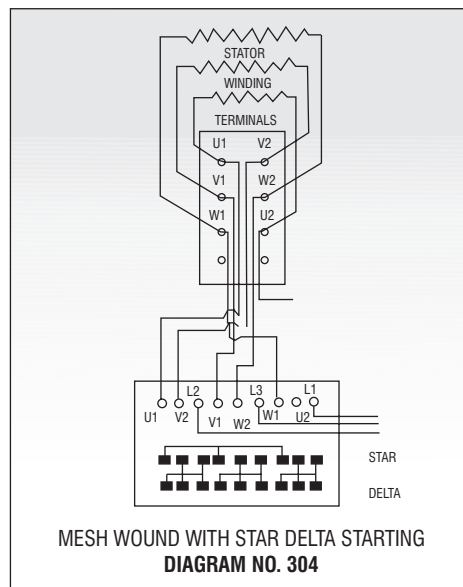
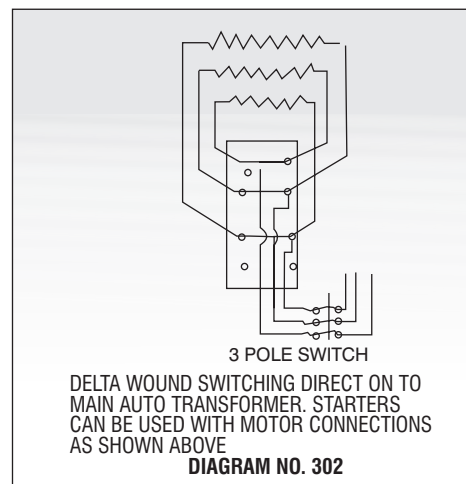
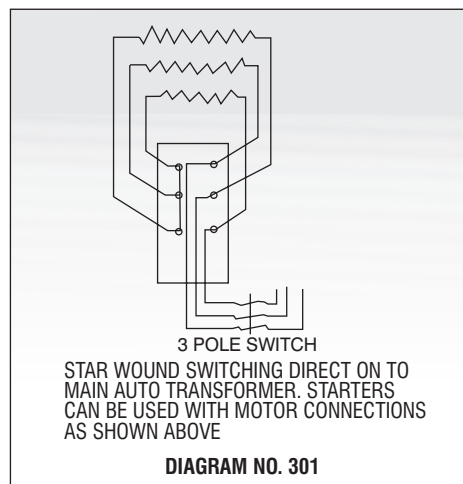
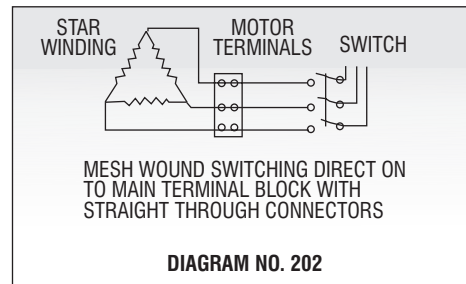
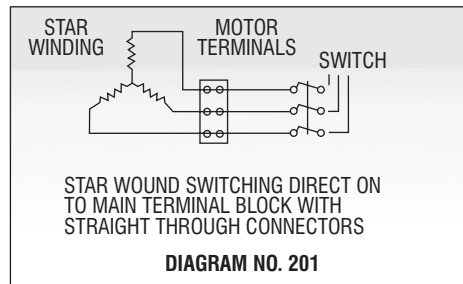

**CONNECTION DIAGRAM FOR
3 PHASE TWO SPEED MOTORS
(SQUIRREL CAGE ROTOR TYPE)**

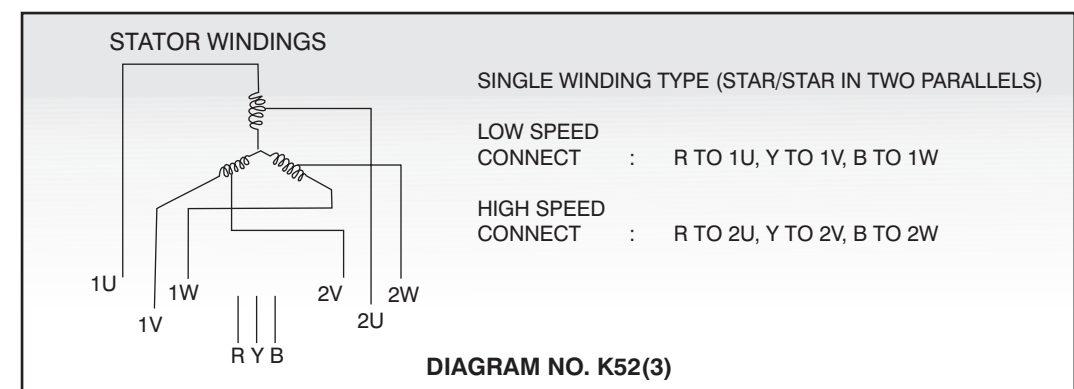
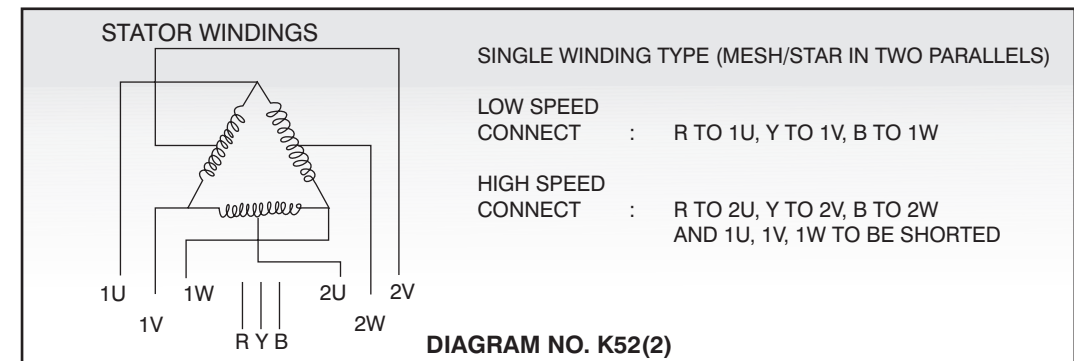
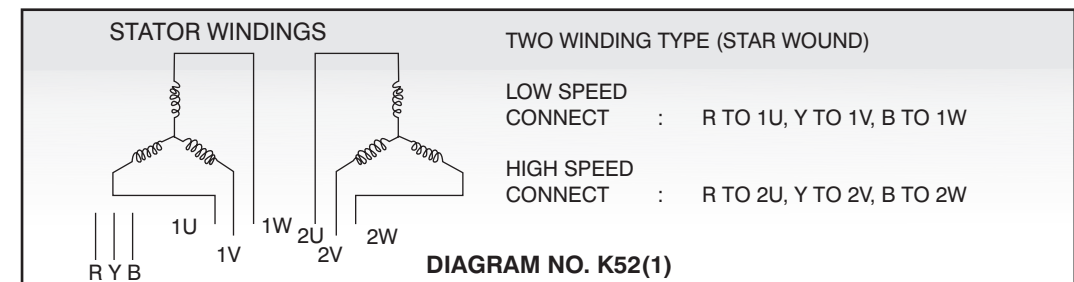

TO REVERSE DIRECTION OF ROTATION - INTERCHANGE LINE LEADS R AND Y

**CONNECTION DIAGRAM FOR
3 PHASE MULTISPEED MOTORS
(SQUIRREL CAGE ROTOR TYPE)**

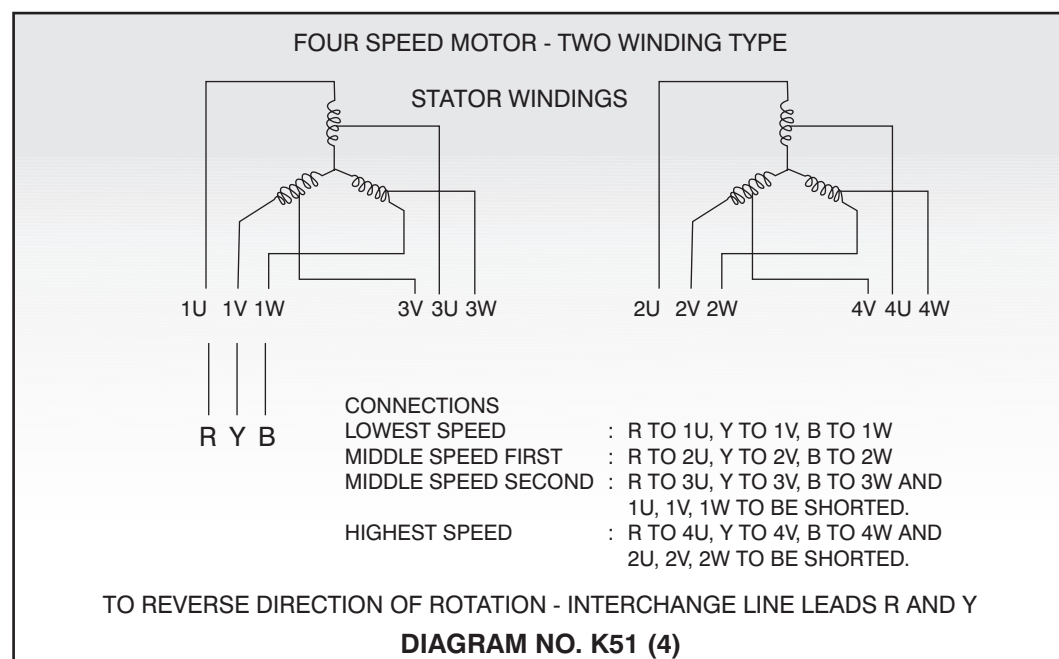
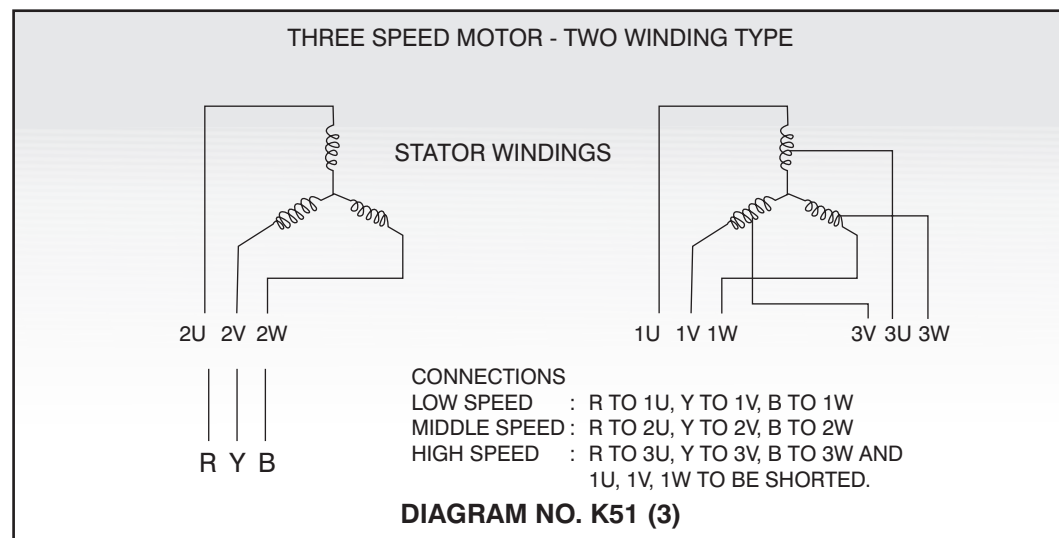

**CONNECTION DIAGRAM FOR
THREE PHASE MULTISPEED MOTORS
(SQUIRREL CAGE ROTOR TYPE)**

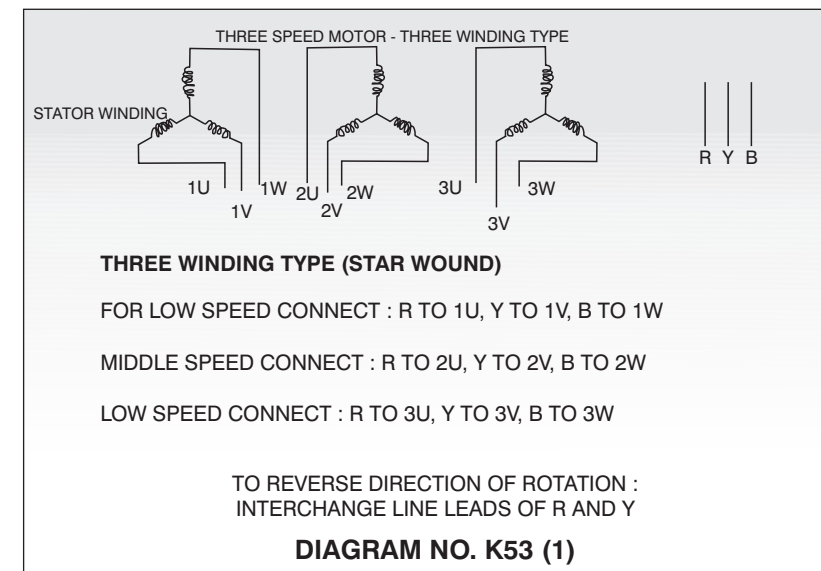

**CONNECTION DIAGRAM FOR
DUAL VOLTAGE MOTORS
(LOWER VOLTAGE $\times \sqrt{3}$ = HIGHER VOLTAGE)**

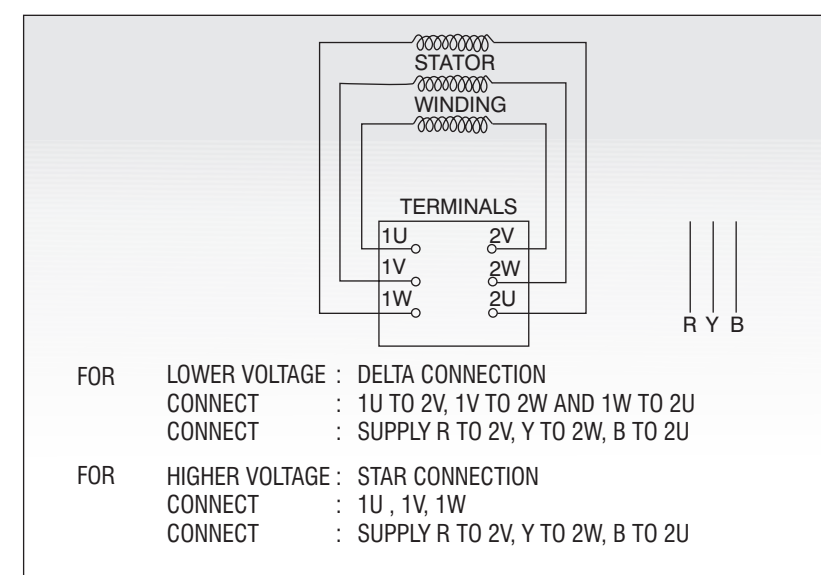

**TERMINAL BOX ARRANGEMENT
FOR FRAMES AD63 AND AD71
(3 LEADS)**

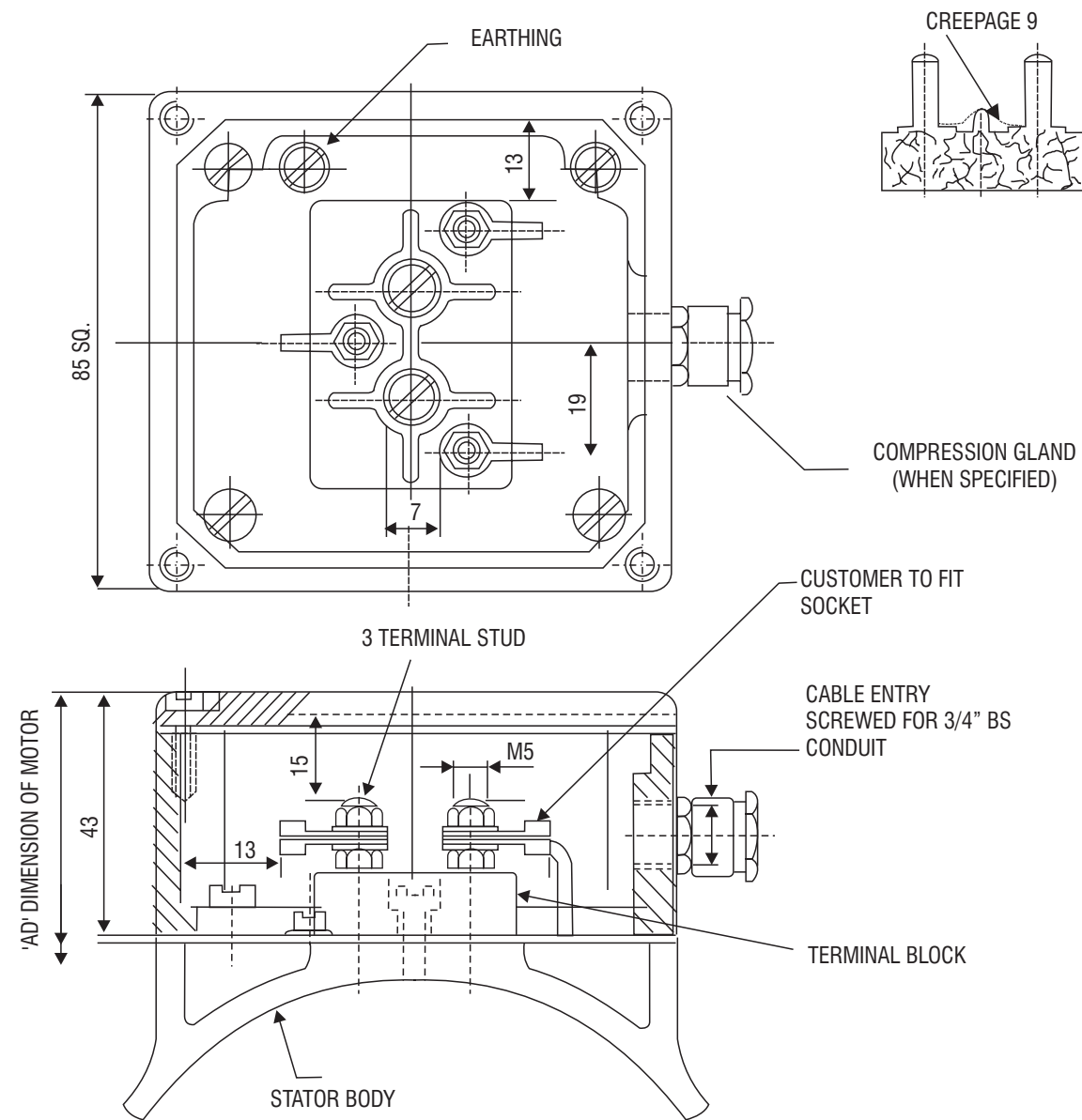

- 1) ALL DIMENSIONS ARE IN mm.
- 2) TERMINAL BOX CAN BE ROTATED THROUGH 360° IN STEPS OF 90°
- 3) DEGREE OF PROTECTION IP 55.

**TERMINAL BOX ARRANGEMENT
FRAMES AD63 AND AD71
(6 LEADS)**

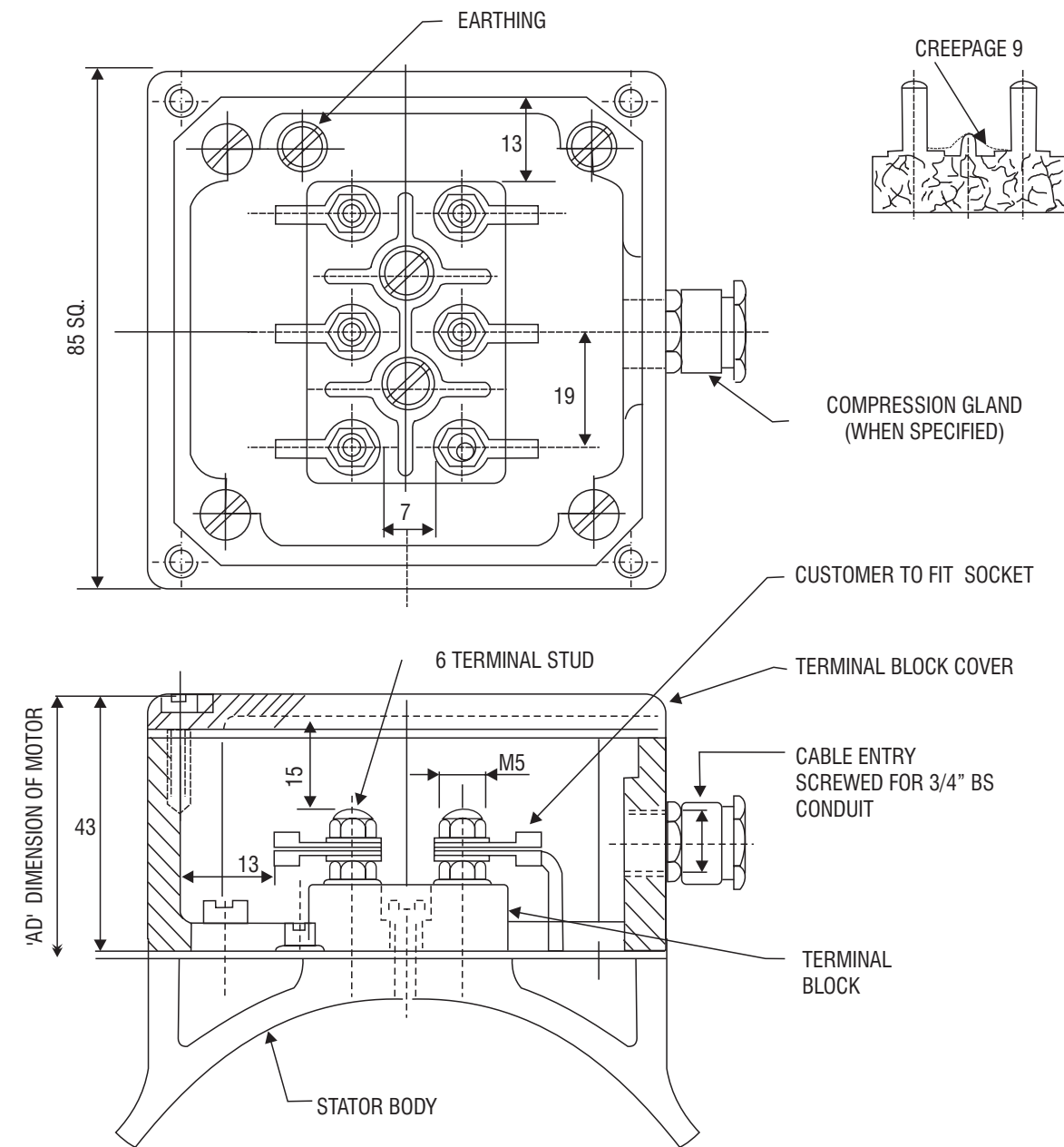

- 1) ALL DIMENSIONS ARE IN mm.
- 2) TERMINAL BOX CAN BE ROTATED THROUGH 360° IN STEPS OF 90°
- 3) DEGREE OF PROTECTION IP 55.

TERMINAL BOX ARRANGEMENT FRAMES AD80

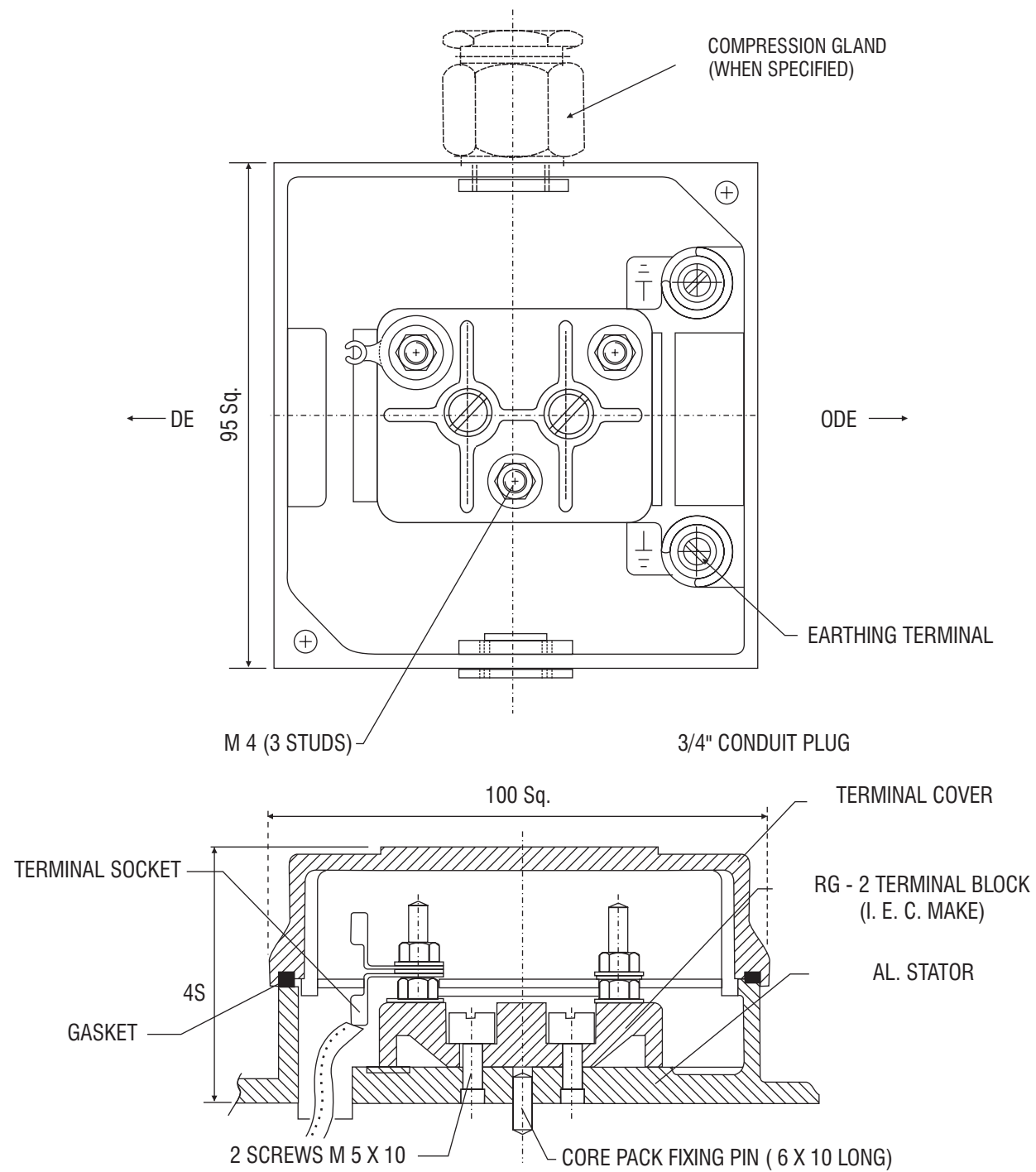

- 1) ALL DIMENSIONS ARE IN mm.
- 2) TERMINAL BOX CAN BE ROTATED THROUGH 360° IN STEPS OF 90°
- 3) DEGREE OF PROTECTION IP 55.

TERMINAL ARRANGEMENT FRAMES ND90 TO ND132 (3 LEADS)

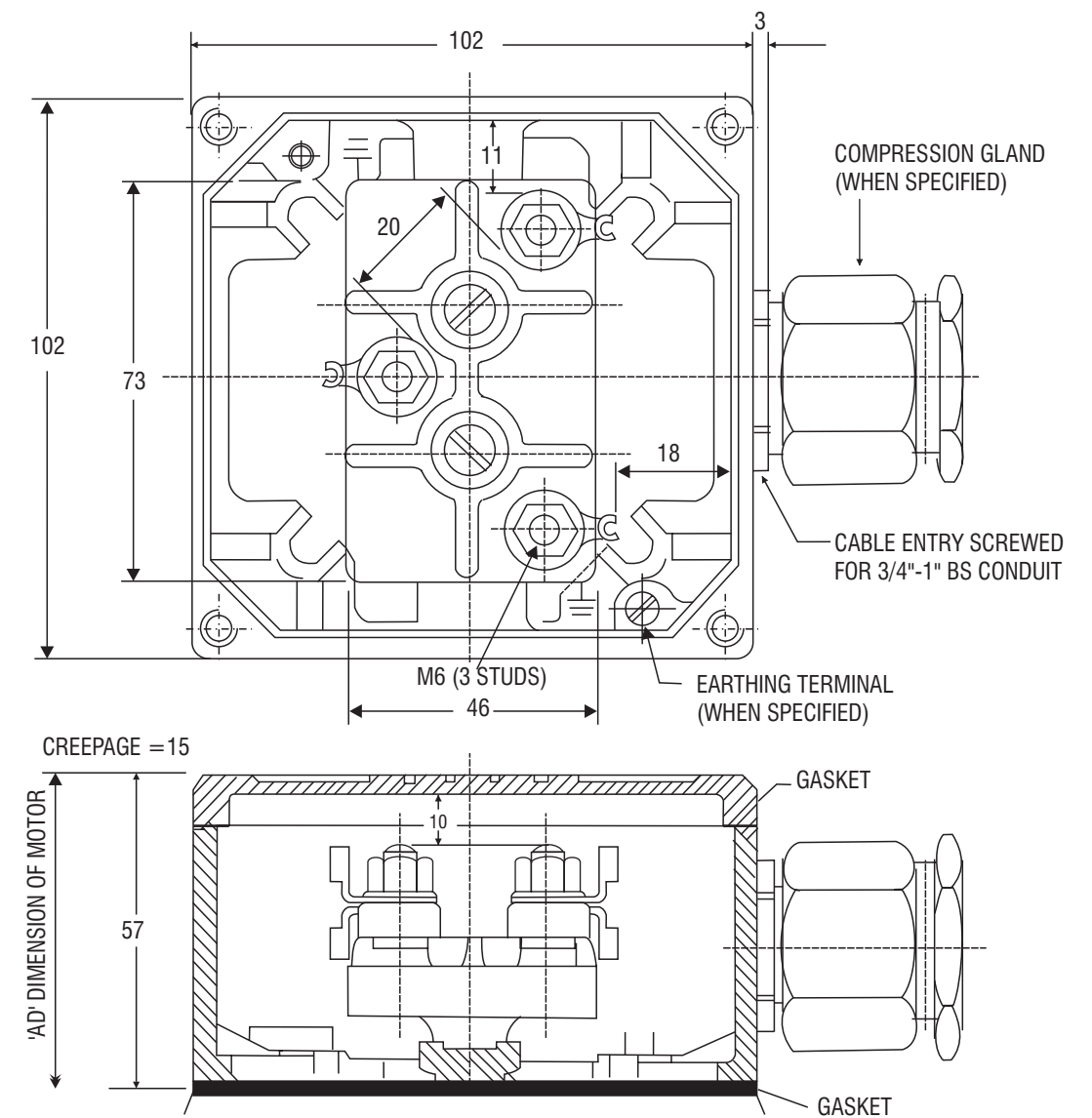

- 1) ALL DIMENSIONS ARE IN mm.
- 2) TERMINAL BOX CAN BE ROTATED THROUGH 360° IN STEPS OF 90°
- 3) DEGREE OF PROTECTION IP 55.

**TERMINAL BOX ARRANGEMENT FOR
FRAMES ND90 TO ND132
(6 LEADS)**

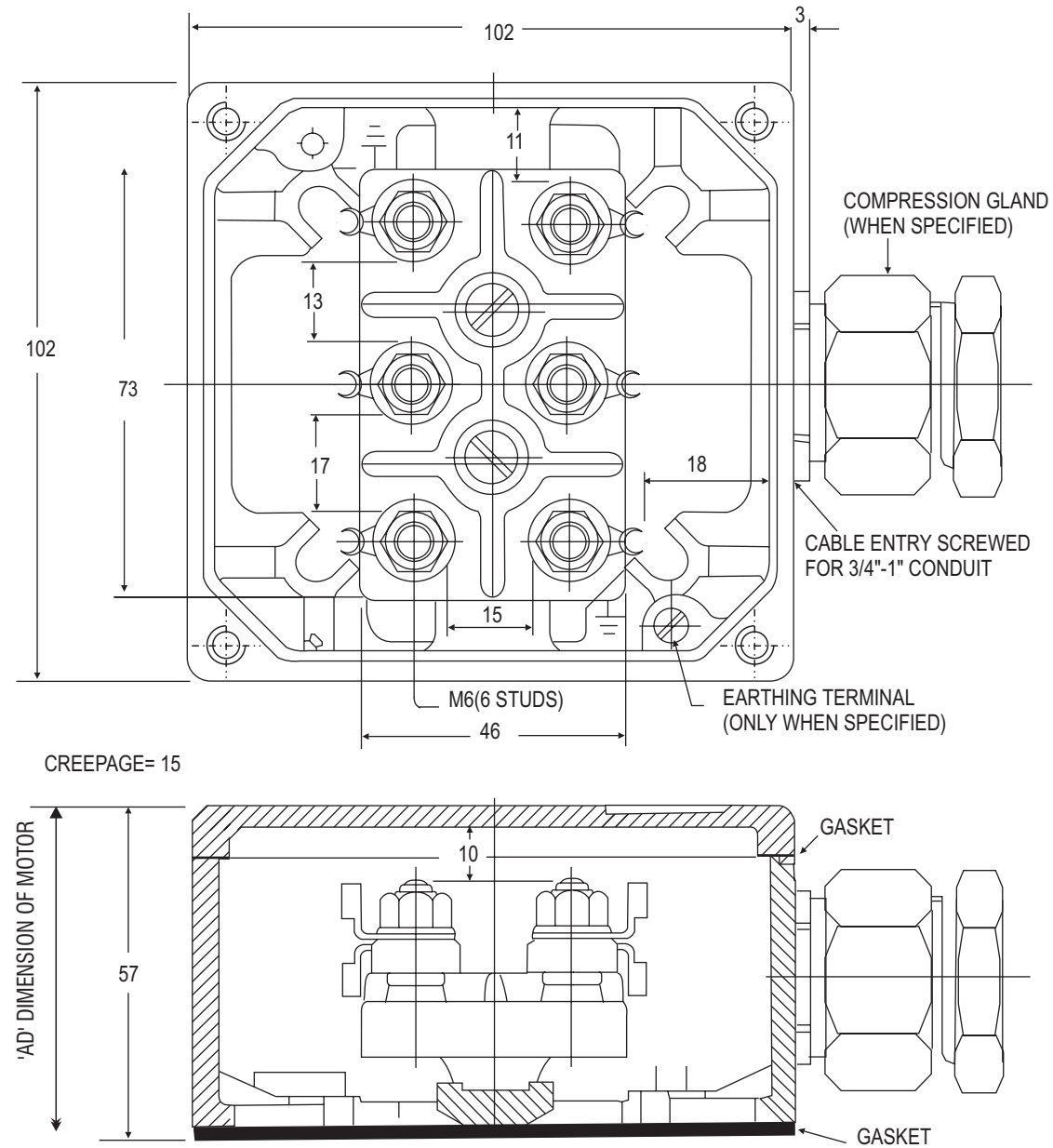

- 1) ALL DIMENSIONS ARE IN mm.
- 2) TERMINAL BOX CAN BE ROTATED THROUGH 360° IN STEPS OF 90°
- 3) DEGREE OF PROTECTION IP 55.

TERMINAL ARRANGEMENT FOR FRAME DW 132 S/M

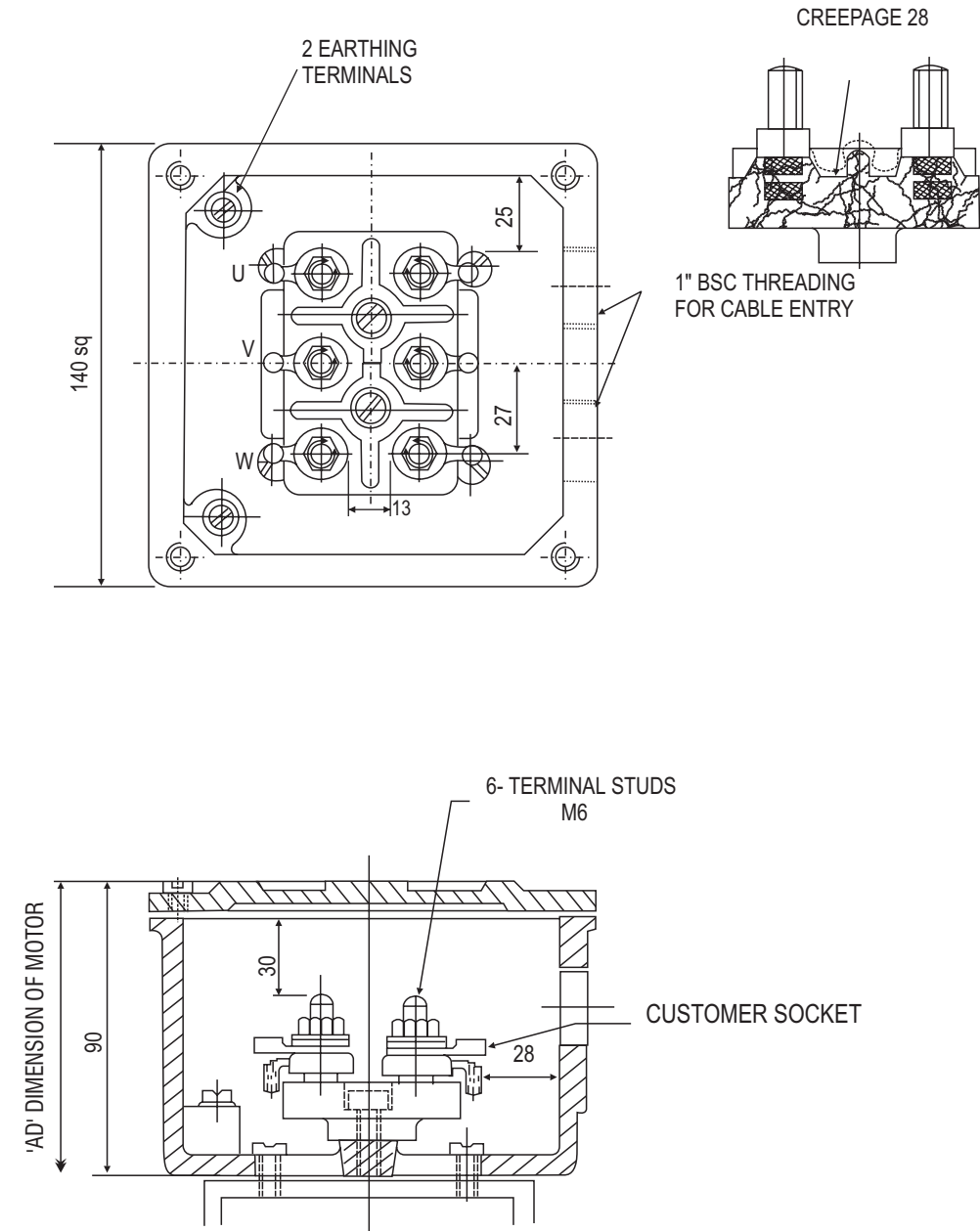

- 1) ALL DIMENSIONS ARE IN mm.
- 2) TERMINAL BOX CAN BE ROTATED THROUGH 360° IN STEPS OF 90°
- 3) DEGREE OF PROTECTION IP 55.

TERMINAL BOX ARRANGEMENT FOR FRAMES ND/C 160, ND/C 180, ND200

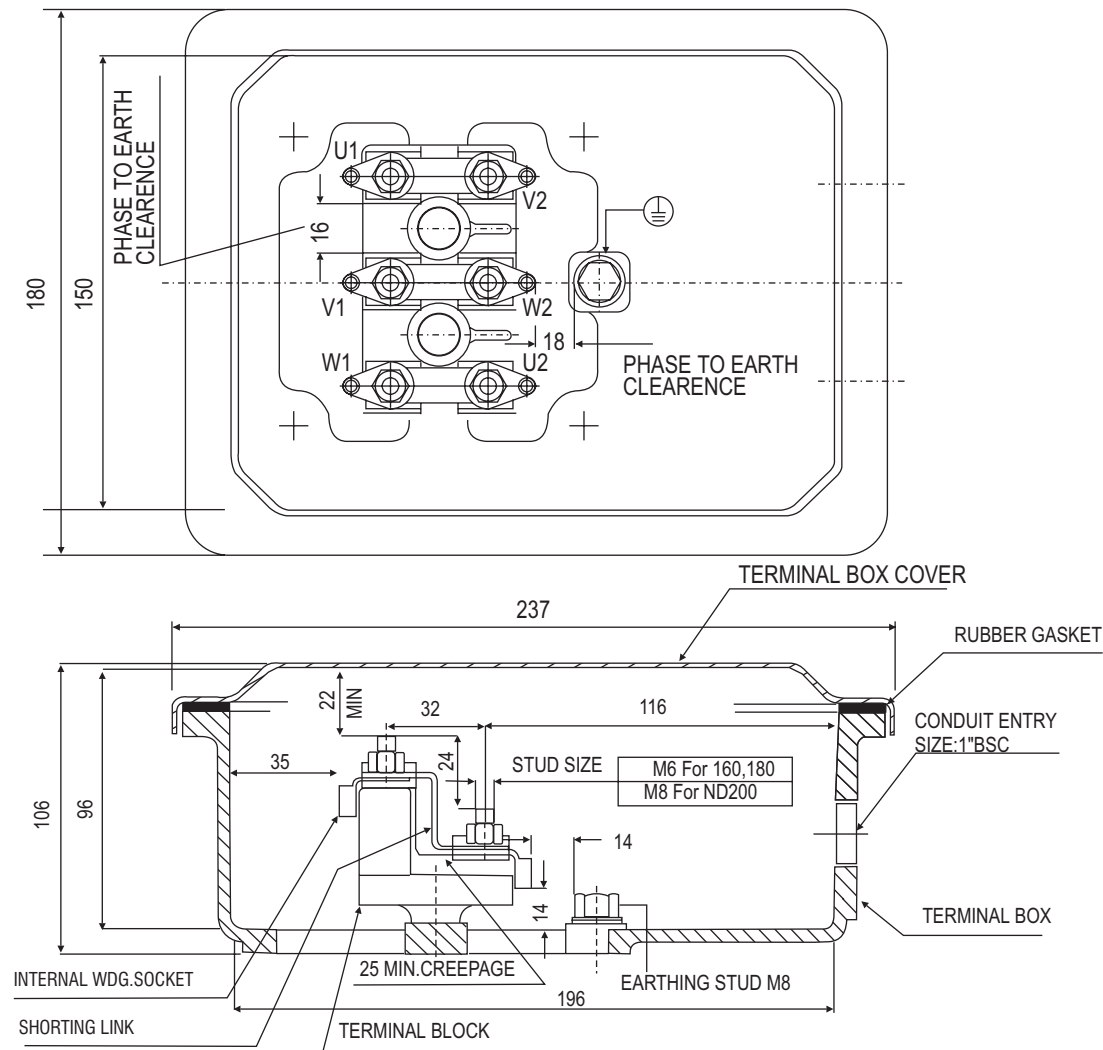

TERMINAL BOX ASSY. ND160-56D

- 1) CUSTOMER SOCKETS OUTSIDE C.G.L. SCOPE OF SUPPLY
- 2) CREEPAGE DISTANCES AND CLEARANCES ARE AS PER BS: 4999 PART 145
- 3) CABLE TYPE: PVC INSULATED, PVC SHEATHED, ARMoured, ALUMINIUM CABLE OF 650/1100V GRADE

TERMINAL BOX ARRANGEMENT FOR FRAMES C200-C250, ND225-ND280

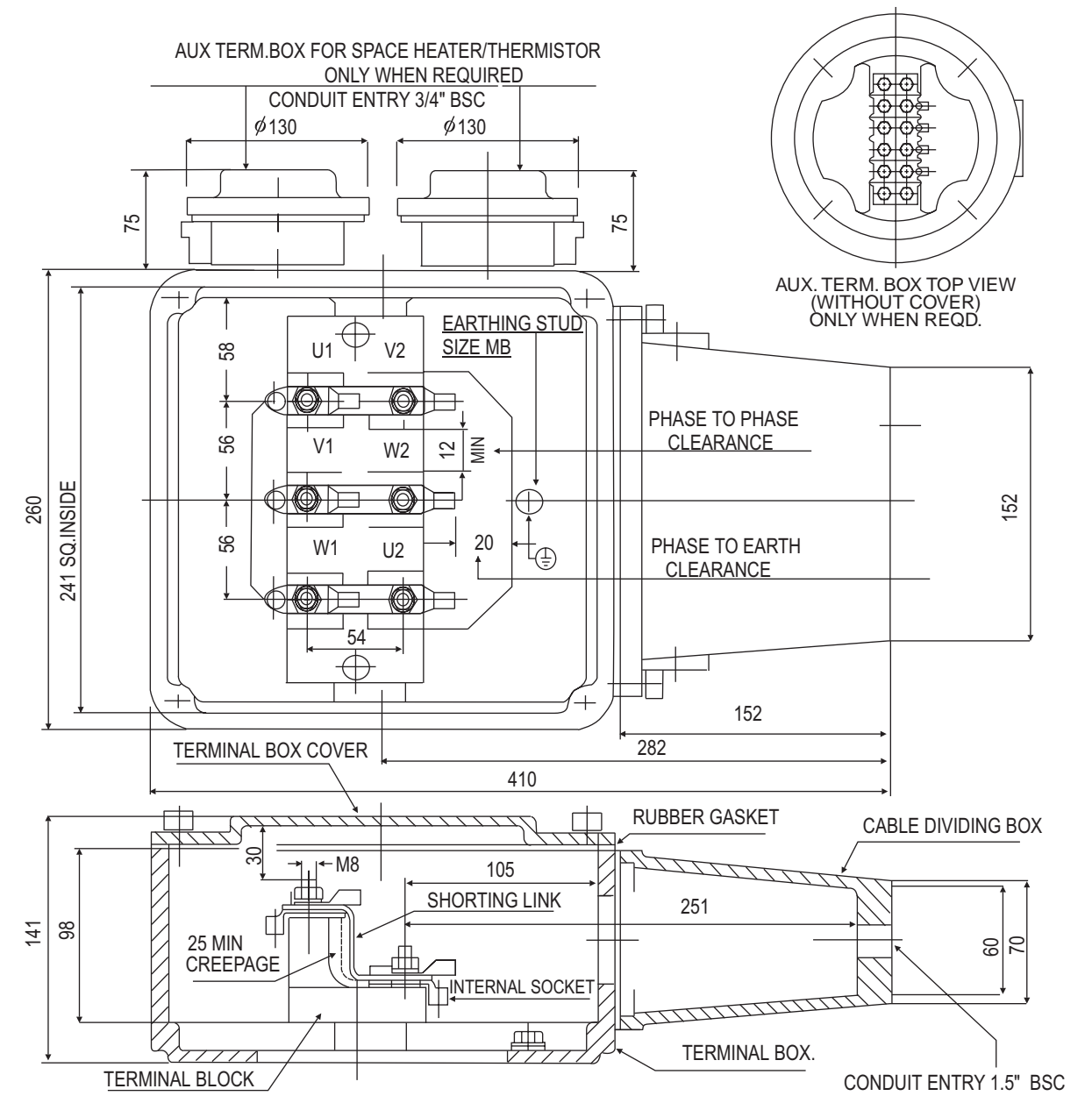

TERMINAL BOX ASSY. 250-38

- 1) CUSTOMER SOCKETS OUTSIDE C.G.L. SCOPE OF SUPPLY
- 2) CREEPAGE DISTANCES AND CLEARANCES ARE AS PER BS:4999 PART 145
- 3) CABLE TYPE : PVC INSULATED, PVC SHEATHED, ARMoured, ALUMINIUM CABLE OF 650/1100V GRADE

TERMINAL BOX ARRANGEMENT FOR FRAMES ND/C280 - ND/C315

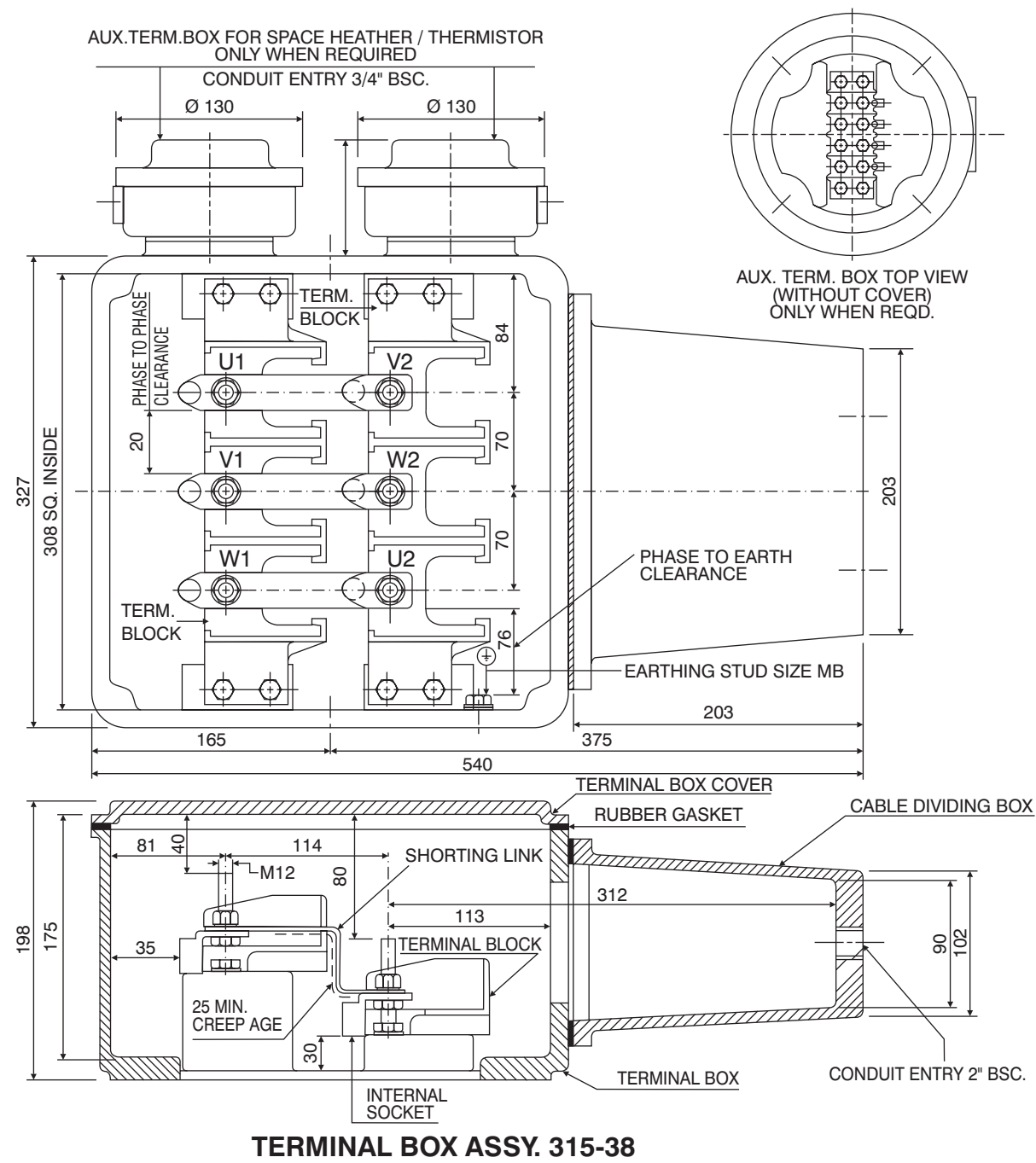

- 1) CUSTOMER SOCKETS OUTSIDE C.G.L SCOPE OF SUPPLY
- 2) CREEP AGE DISTANCES AND CLEARANCES ARE AS PER BS:4999 PART 145
- 3) CABLE TYPE : PVC INSULATED, PVC SHEATHED, ARMoured, ALUMINIUM CABLE OF 650/1100V GRADE

TERMINAL BOX ARRANGEMENT FOR FRAMES ND315L-355LX, C315MX

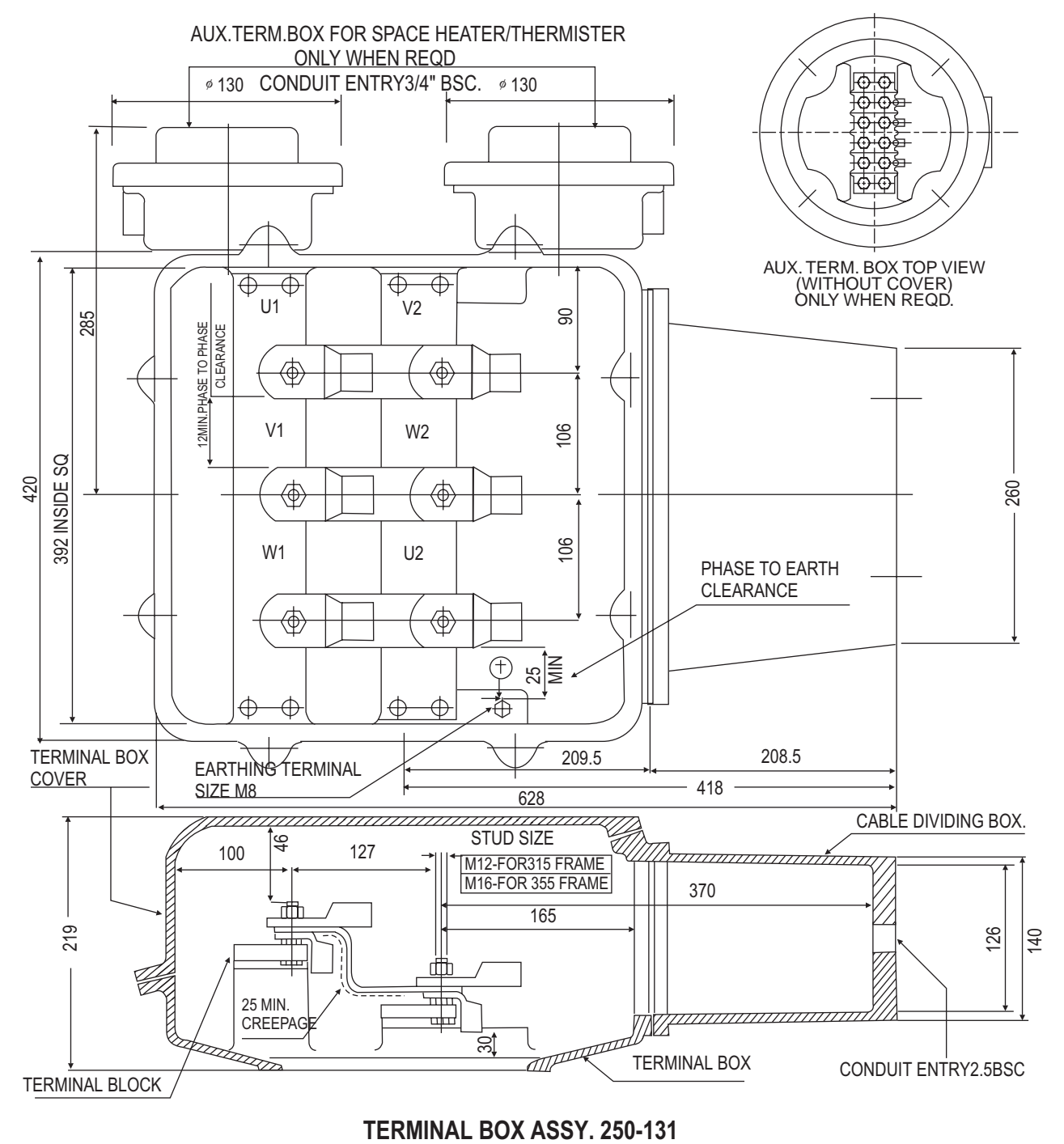

- 1) CUSTOMER SOCKETS OUTSIDE C.G.L SCOPE OF SUPPLY
- 2) CREEPAGE DISTANCES AND CLEARANCES ARE AS PER BS:4999 PART 145
- 3) CABLE TYPE : PVC INSULATED, PVC SHEATHED, ARMoured, ALUMINIUM CABLE OF 650/1100V GRADE

PERFORMANCE DATA

**PERFORMANCE DATA
3 - PHASE TEFC SCR INDUCTION MOTOR**

VOLTAGE : 415 ± 10% V TYPE : SQUIRREL CAGE (SCR) AMBIENT : 50 DEG C
 FREQUENCY : 50 ± 5% Hz RATING : CONTINUOUS TEMP. RISE (R) : 70 DEG C
 COMBINED : ± 10 % (ABSOLUTE INSULATION : CLASS 'F' WITH CLASS 'B' DEGREE OF : IP55
 VARIATION SUM) TEMP. RISE PROTECTION

OUTPUT	P O L E	FRAME SIZE	FL RPM	FLC AMPS.	FLT Kg-m	EFFICIENCY (%)			POWER FACTOR			DOL STG.		POT % FLT	GD. ² KGM. ²	NET WT. KG	
						FL	3/4 LOAD	1/2 LOAD	FL	3/4 LOAD	1/2 LOAD	STG.T % FLT	STG.C % FLC				
0.18	2	AD63	2700	0.50	0.06	64.0	62.0	58.0	0.79	0.68	0.59	300	500	350	0.001	5.6	
		AD63	1330	0.50	0.13	64.0	62.0	58.0	0.76	0.73	0.60	200	400	250	0.003	5.6	
		AD71	900	0.55	0.19	65.0	64.0	60.0	0.68	0.60	0.50	200	400	250	0.004	7.0	
0.25	2	AD63	2700	0.65	0.09	68.0	67.0	63.0	0.79	0.72	0.60	275	500	325	0.001	5.6	
		AD71	1350	0.75	0.18	62.0	61.0	55.0	0.76	0.73	0.60	225	400	275	0.004	7.0	
0.37	2	AD71	2820	0.95	0.13	68.0	67.0	63.0	0.79	0.72	0.60	275	500	325	0.002	7.0	
		AD71	1400	0.90	0.26	77.0	76.0	74.0	0.76	0.73	0.60	225	600	275	0.004	7.0	
		AD/D80	910	1.05	0.40	69.0	68.0	66.0	0.71	0.63	0.52	210	400	260	0.011	10/17	
		ADND90S	680	1.40	0.53	65.0	64.0	60.0	0.57	0.50	0.40	170	400	220	0.015	13/22	
0.55	2	AD/D80	2820	1.30	0.19	73.0	72.0	68.0	0.81	0.73	0.62	250	600	300	0.003	10/17	
		AD/D80	1410	1.25	0.38	77.0	76.0	74.0	0.78	0.75	0.64	200	500	250	0.007	10/17	
		AD/D80	910	1.55	0.59	69.0	68.0	66.0	0.71	0.63	0.52	210	400	260	0.011	10/17	
		AD/ND90L	680	1.75	0.79	69.0	68.0	64.0	0.63	0.54	0.45	150	400	200	0.021	13/22	
0.75	2	AD/D80	2820	1.65	0.26	77.0	76.0	74.0	0.81	0.73	0.62	300	600	350	0.003	10/17	
		AD/D80	1410	1.75	0.52	77.0	76.0	74.0	0.78	0.75	0.64	200	500	250	0.007	10/17	
		AD/ND90S	935	2.00	0.78	73.0	71.0	69.0	0.72	0.65	0.58	200	400	250	0.015	13/22	
		AD/ND100L	700	2.55	1.04	70.0	69.0	64.0	0.58	0.51	0.41	200	400	250	0.030	19/32	
1.10	2	AD/D80	2820	2.35	0.38	79.0	78.0	76.0	0.82	0.77	0.70	225	600	275	0.004	10/17	
		AD/ND90S	1415	2.50	0.76	78.0	76.0	74.0	0.78	0.75	0.64	200	500	250	0.014	13/22	
		AD/ND90L	935	2.85	1.15	74.0	73.0	70.0	0.72	0.65	0.58	200	400	250	0.021	16/25	
		AD100L/ ND100L	700	3.30	1.53	72.5	71.0	68.0	0.63	0.54	0.44	175	400	225	0.034	19/35	
1.50	2	AD/ND90S	2830	3.20	0.52	80.0	79.0	77.0	0.82	0.77	0.70	225	600	275	0.006	13/22	
		AD/ND90L	1415	3.20	1.03	80.0	79.0	77.0	0.81	0.78	0.71	200	500	250	0.019	16/25	
		AD/ND100L	935	3.80	1.56	76.0	75.0	73.0	0.72	0.65	0.58	200	400	250	0.030	19/32	
		AD112M/ ND112M	700	4.00	2.09	77.0	77.0	75.0	0.68	0.60	0.52	190	400	240	0.057	29/45	
2.20	2	AD/ND90L	2830	4.60	0.76	81.0	80.0	78.0	0.82	0.77	0.70	300	600	350	0.008	16/25	
		AD/ND100L	1440	4.60	1.49	82.0	81.0	79.0	0.82	0.78	0.72	200	600	250	0.030	19/32	
		AD/ND112M	935	5.30	2.29	77.0	76.0	73.0	0.75	0.70	0.60	200	500	250	0.048	29/42	
		ND132S	710	5.40	3.02	77.5	76.5	73.0	0.73	0.68	0.61	180	450	230	0.174	68.0	
3.70	2	AD/ND100L	2875	7.60	1.25	83.0	82.0	80.0	0.82	0.77	0.70	250	650	300	0.022	19/36	
		AD/ND112M	1440	7.60	2.50	84.0	83.0	81.0	0.81	0.76	0.69	200	600	250	0.052	29/42	
		ND132S	950	7.70	3.79	85.0	84.0	82.0	0.79	0.73	0.63	200	600	250	0.174	68.0	
		ND132M	710	8.60	5.08	80.0	80.0	78.0	0.75	0.70	0.60	180	600	230	0.214	79.0	
5.50	2	AD/ND112M	2880	10.10	1.86	85.0	84.0	82.0	0.89	0.85	0.80	250	650	300	0.034	29/45	
		ND132S	1450	10.10	3.69	86.0	85.0	83.0	0.88	0.85	0.75	250	600	300	0.131	68.0	
		ND132M	950	11.30	5.64	85.0	84.0	82.0	0.80	0.75	0.68	200	600	250	0.214	79.0	
7.50	2	ND132S	2890	13.80	2.53	85.0	84.0	82.0	0.89	0.85	0.80	275	650	325	0.062	68.0	
		ND132M	1455	13.60	5.02	87.0	86.0	84.0	0.88	0.85	0.75	275	600	325	0.161	79.0	
9.30	12.50	2	# ND132M	2890	16.70	3.13	87.0	86.0	84.0	0.89	0.85	0.80	275	600	325	0.076	79.0

NOTE : ALL PERFORMANCE FIGURES ARE SUBJECT TO TOLERANCES AS PER IS325
 # FOR 45°C / 75°C ONLY.

**PERFORMANCE DATA
3 - PHASE TEFC SCR INDUCTION MOTOR**

VOLTAGE : 415 ± 10% V TYPE : SQUIRREL CAGE (SCR) AMBIENT : 50 DEG C
 FREQUENCY : 50 ± 5% Hz RATING : CONTINUOUS TEMP. RISE (R) : 70 DEG C
 COMBINED : ± 10 % (ABSOLUTE INSULATION : CLASS 'F' WITH CLASS 'B' DEGREE OF : IP55
 VARIATION SUM) TEMP. RISE PROTECTION

OUTPUT	P O L E	FRAME SIZE	FL RPM	FLC AMPS.	FLT Kg-m	EFFICIENCY (%)			POWER FACTOR			DOL STG.		POT % FLT	GD. ² KGM. ²	NET WT. KG		
						FL	3/4 LOAD	1/2 LOAD	FL	3/4 LOAD	1/2 LOAD	STG.T % FLT	STG.C % FLC					
3.7	5.0	8	ND160M	710	8.0	5.08	83.0	83.0	81.0	0.74	0.70	0.62	150	500	200	0.46	125	
			5.5	7.5	6	ND160M	970	11.0	5.52	86.0	86.0	84.0	0.80	0.76	0.68	200	550	250
		8	ND160M		710	12.0	7.55	85.0	85.0	83.0	0.74	0.70	0.62	150	500	200	0.46	125
7.5	10.0	2	ND160M	2910	14.0	2.51	85.0	84.0	82.0	0.88	0.86	0.78	225	600	275	0.13	125	
			4	ND160M	1460	14.0	5.00	87.0	87.0	85.0	0.85	0.81	0.73	225	600	275	0.31	125
			6	ND160M	975	15.0	7.49	87.5	87.0	85.0	0.80	0.76	0.68	200	550	250	0.46	125
			8	ND160L	710	16.0	10.29	85.0	85.0	83.0	0.76	0.72	0.64	150	500	200	0.64	148
9.3	12.5	2	ND160M	2920	17.0	3.10	87.0	87.0	85.0	0.88	0.86	0.78	250	650	300	0.13	125	
			4	ND160M	1460	17.0	6.20	88.5	88.5	86.5	0.84	0.81	0.73	175	600	225	0.31	125
			6	ND160L	975	18.0	9.29	87.5	87.0	84.0	0.80	0.76	0.68	200	550	250	0.59	148
			8	ND180M	720	20.0	12.58	86.0	86.0	84.0	0.74	0.70	0.60	175	500	225	0.99	174
11	15	2	ND160M	2920	20.0	3.67	88.0	88.0	86.0	0.88	0.86	0.78	250	650	300	0.13	125	
			4	ND160M	1460	21.0	7.34	89.0	89.0	86.0	0.82	0.79	0.70	200	600	250	0.36	125
			6	ND160L	975	22.0	10.99	88.0	87.5	86.0	0.80	0.76	0.68	200	550	250	0.64	148
			8	ND180L	720	24.0	14.88	87.0	87.0	85.0	0.74	0.70	0.60	175	500	225	1.16	210
15	20	2	ND160M	2920	26.0	5.00	89.5	89.5	87.5	0.88	0.86	0.79	250	650	300	0.17	125	
			#	ND160L	1460	27.0	10.01	90.0	90.0	88.0	0.85	0.83	0.75	200	600	250	0.47	148
			6	ND180L	975	29.0	14.98	90.0	90.0	88.0	0.79	0.73	0.66	225	600	275	1.16	210
			8	ND200L	725	33.0	20.15	88.5	88.5	86.5	0.71	0.65	0.55	225	500	275	2.14	282
18.5	25	2	ND160L	2920	32.0	6.17	90.0	90.0	88.0	0.88	0.86	0.79	275	650	325	0.21	148	
			4	ND180M	1475	33.0	12.22	92.0	92.0	90.0	0.84	0.80	0.72	200	600	250	0.81	174
			6	ND200L	975	34.0	18.48	91.1	91.1	89.9	0.84	0.82	0.73	200	550	250	1.69	282
			8	ND225S	725	39.0	24.85	89.0	89.0	87.0	0.75	0.71	0.63	175	500	225	3.24	345
22	30	2	ND180M	2930	41.0	7.31	91.0	91.0	89.0	0.83	0.80	0.72	225	600	275	0.44	164	
			4	ND180L	1475	40.0	14.53	92.0	92.0	90.0	0.84	0.80	0.72	200	600	250	0.95	210
			6	ND200L	975	40.0	21.98	91.5	91.5	90.1	0.84	0.82	0.78	200	550	250	2.04	282
			8	ND225M	725	46.0	29.56	89.0	89.0	87.0	0.75	0.71	0.63	175	550	225	3.61	375
30	40	2	ND200L	2950	51.0	9.91	91.5	91.5	90.0	0.90	0.89	0.87	200	600	250	0.80	282	
			4</															

PERFORMANCE DATA									
3 - PHASE TEFC SCR INDUCTION MOTOR									
VOLTAGE	: 415 ± 10% V	TYPE	: SQUIRREL CAGE (SCR)	AMBIENT	: 50 DEG C				
FREQUENCY	: 50 ± 5% Hz	RATING	: CONTINUOUS	TEMP. RISE (R)	: 70 DEG C				
COMBINED VARIATION	: ± 10 % (ABSOLUTE SUM)	INSULATION	: CLASS 'F' WITH CLASS 'B'	DEGREE OF PROTECTION	: IP55				

OUTPUT kW	HP	P O L E	FRAME SIZE	FL RPM	FLC AMPS.	FLT Kg-m	EFFICIENCY (%)			POWER FACTOR			DOL STG.		POT % FLT	GD. ² KGM. ²	NET WT. KG
							FL	3/4 LOAD	1/2 LOAD	FL	3/4 LOAD	1/2 LOAD	STG.T % FLT	STG.C % FLC			
90	120	2	ND280M	2975	148.0	29.47	94.0	94.0	92.5	0.90	0.86	0.78	225	600	275	8.18	670
		4	ND280M	1480	147.0	59.23	94.5	94.5	92.5	0.90	0.88	0.84	250	600	300	8.26	670
		6	ND315M	987	155.0	88.81	94.2	94.2	93.5	0.86	0.82	0.74	250	600	300	17.00	950
		8	ND315L	740	178.0	118.46	94.0	94.0	92.0	0.75	0.72	0.68	250	600	300	29.85	1160
110	150	2	ND315S	2965	173.0	36.13	94.0	94.0	92.5	0.94	0.91	0.84	200	600	250	6.63	900
		4	ND315S	1488	176.0	72.00	94.5	94.5	92.0	0.92	0.88	0.80	225	600	275	11.62	900
		6	ND315M	987	188.0	108.55	94.5	94.5	93.5	0.86	0.82	0.74	250	600	300	18.98	950
		8	ND315L	740	217.0	144.78	94.0	94.0	92.0	0.75	0.72	0.68	250	600	300	29.85	1160
132	180	2	ND315M	2965	208.0	43.36	94.0	94.0	92.5	0.94	0.90	0.82	200	600	250	7.97	950
		4	ND315M	1488	210.0	86.40	95.0	95.0	94.0	0.92	0.88	0.80	225	600	275	13.98	950
		6	ND315L	985	226.0	130.53	94.5	94.5	93.5	0.86	0.82	0.74	250	600	300	29.85	1160
		8	ND315L	740	259.0	173.74	94.5	94.5	92.5	0.75	0.72	0.68	225	600	275	29.85	1160
150	200	2	ND315L	2975	235.0	49.11	94.5	94.5	92.5	0.94	0.92	0.90	175	600	225	16.37	1160
		4	ND315M	1488	239.0	98.19	95.0	95.0	94.0	0.92	0.88	0.80	225	600	275	15.61	950
		6	ND315L	990	257.0	147.58	94.5	94.5	93.5	0.86	0.82	0.74	250	600	300	29.85	1160
		8	ND355L	740	296.0	197.43	94.0	93.0	91.0	0.75	0.72	0.68	150	600	200	33.16	2150
160	215	2	ND315L	2975	249.0	52.38	95.0	94.5	93.5	0.94	0.92	0.90	175	600	225	16.37	1160
		4	ND315L	1490	260.0	104.59	95.3	95.3	94.0	0.90	0.86	0.78	200	600	250	24.97	1160
		6	ND315L	990	274.0	157.41	94.5	94.5	93.5	0.86	0.82	0.74	250	600	300	29.85	1160
		8	ND355L	740	316.0	210.59	94.0	93.0	91.0	0.75	0.72	0.68	175	600	225	36.73	2150
180	240	2	ND315L	2975	280.0	58.93	95.0	94.5	93.5	0.94	0.92	0.90	200	600	250	16.37	1160
		4	ND315L	1490	293.0	117.66	95.0	95.0	94.0	0.90	0.88	0.84	225	600	275	24.97	1160
		6	ND355L	990	315.0	177.09	94.5	93.5	91.0	0.84	0.81	0.72	225	600	275	33.16	2150
		8	ND355LX	745	353.0	235.33	94.5	94.5	92.5	0.75	0.72	0.68	135	500	185	61.40	2100
200	270	2	ND315L	2975	310.0	65.48	95.5	95.5	94.0	0.94	0.92	0.90	200	600	250	16.37	1160
		4	ND315L	1490	324.0	130.74	95.5	95.5	94.0	0.90	0.88	0.84	225	600	275	24.97	1160
		6	ND355LX	991	351.0	196.57	94.5	93.5	91.0	0.84	0.81	0.72	150	600	200	55.26	2150
		8	ND355LX	745	403.0	261.48	94.5	94.5	92.5	0.73	0.66	0.56	135	500	185	61.40	2150
225	302	2	ND355L	2980	341.0	73.54	95.5	95.5	94.0	0.96	0.92	0.88	175	600	225	25.70	2150
		4	ND355L	1490	372.0	147.08	95.5	95.5	94.0	0.88	0.86	0.82	185	600	235	35.57	2150
		6	ND355LX	991	394.0	221.14	94.5	94.5	92.0	0.84	0.81	0.73	150	600	200	61.40	2150
		8	ND355LX	745	454.0	294.16	94.5	94.5	92.5	0.73	0.66	0.56	135	500	185	61.40	2150
250	335	2	ND355LX	2980	379.0	81.71	95.5	95.0	93.5	0.96	0.92	0.88	175	650	225	25.70	2150
		4	ND355L	1490	413.0	163.42	95.7	95.7	94.5	0.88	0.86	0.82	185	600	235	35.57	2150
		6	ND355LX	993	434.0	245.22	95.5	95.0	94.0	0.84	0.81	0.73	150	600	200	61.40	2150
315	425	2	ND355LX	2980	478.0	102.96	95.5	95.5	94.0	0.96	0.92	0.88	200	600	250	30.70	2150
		4	ND355LX	1492	496.0	205.64	96.0	96.0	94.5	0.92	0.90	0.88	175	600	225	39.52	2150
275	369	6	ND355LX	990	477.0	270.56	95.5	95.0	94.0	0.84	0.81	0.73	150	600	200	39.52	2150

STG.C = Starting Current; STG.T = Starting Torque

THESE RATINGS CAN BE GIVEN WITH 95° RISE AT 45° AMBIENT

75	100	4	ND250M	1475	125.0	49.53	93.5	93.5	92.0	0.89	0.86	0.82	200	600	250	3.80	520
110	150	4	ND280M	1480	180.0	72.39	94.5	94.5	92.5	0.90	0.88	0.84	250	600	300	8.26	700

NOTE : ALL PERFORMANCE FIGURES ARE SUBJECT TO TOLERANCES AS PER IS325

OUTPUT kW	HP	P O L E	FRAME SIZE	FL RPM	FLC AMPS.	FLT Kg-m	EFFICIENCY (%)			POWER FACTOR			DOL STG.		POT % FLT	GD. ² KGM. ²	NET WT. KG
							FL	3/4 LOAD	1/2 LOAD	FL	3/4 LOAD	1/2 LOAD	STG.T % FLT	STG.C % FLC			
3.7	5.0	8	C160M	700	9.0	5.1	82.0	81.0	79.0	0.74	0.70	0.62	500	150	200	0.55	121
5.5	7.5	8	C160M	700	13.0	7.7	82.0	81.0	79.0	0.74	0.70	0.62	500	150	200	0.55	121
7.5	10.0	6	C160M	940	16.0	7.8	83.0	82.0	80.0	0.79	0.75	0.66	500	200	250	0.42	121
		8	C160L	700	17.0	10.4	82.0	81.0	79.0	0.74	0.70	0.62	500	150	200	0.65	131
9.3	12.5	2	C160M	2900	19.0	3.1	84.0	83.0	81.0	0.82	0.78	0.70	550	200	250	0.16	121
		4	C160M	1450	19.0	6.2	86.0	85.0	83.0	0.82	0.78	0.72	550	170	220	0.38	121
		6	C160L	940	19.0	9.6	84.0	83.0	81.0	0.80	0.76	0.68	500	200	250	0.54	131
		8	C180M	700	20.0	12.9	84.0	83.0	81.0	0.76	0.72	0.64	500	150	200	1.14	185
11.0	15.0	2	C160M	2900	22.0	3.7	84.0	83.0	81.0	0.82	0.78	0.70	550	200	250	0.16	121
		4	C160M	1460	21.0	7.3	87.0	86.0	84.0	0.84	0.80	0.74	550	170	220	0.38	121
		6	C160L	940	22.0	11.4	84.0	83.0	81.0	0.82	0.78	0.70	500	200	250	0.62	131
		8	C180M	700	24.0	15.3	85.0	84.0	82.0	0.76	0.72	0.64	500	150	200	1.14	185
15.0	20.0	2	C160M	2900	29.0	5.0	85.0	84.0	82.0	0.85	0.81	0.75	550	200	250	0.17	121
		4	C160L	1460	28.0	10.0	90.0	90.0	88.0	0.84	0.80	0.74	550	175	225	0.48	131
		6	C180M	955	31.0	15.3	84.5	84.0	82.0	0.81	0.75	0.67	600	200	250	1.14	185
		8	C180L	700	32.0	20.9	85.0	84.0	82.0	0.76	0.72	0.64	500	150	200	1.45	205
18.5	25.0	2	C160L	2920	36.0	6.2	85.0	84.0	82.0	0.84	0.80	0.72	550	200	250	0.22	131
		4	C160L	1460	35.0	12.3	89.0	88.0	86.0	0.84	0.80	0.74	550	170	220	0.68	131
		6	C180L	960	35.0	18.8	87.0	86.0	84.0	0.85	0.81	0.73	600	200	250	1.33	205
		8	C200M	720	41.0	25.0	86.0	85.0	83.0	0.74	0.70	0.62	500	150	200	2.20	260
22.0	30.0	2	C160L	2920	41.0	7.3	88.0	87.0	86.0	0.84	0.80	0.75	550	175	225	0.28	131
		4	C180M	1450	43.0	14.8	87.0	86.0	84.0	0.82	0.78	0.70	600	200	250	0.91	185
		6	C200M	960	42.0	22.3	89.0	88.0	86.0	0.82	0.80	0.74	600	170	220	1.91	260
		8	C200L	720	48.0	29.8	87.0	86.0	84.0	0.74	0.70	0.62	500	150	200	2.58	300
30.0	40.0	2	C180M	2935	51.0	10.0	89.0	88.0	86.0	0.92	0.88	0.80	600	200	250	0.49	185
		4	C180L	1450	55.0	20.2	88.0	87.0	85.0	0.86	0.82	0.74	600	200	250	1.15	205
		6	C200L	970	57.0	30.1	89.0	88.0	86.0	0.82	0.80	0.74	600	170	220	2.58	300
		8	C225M	720	64.0	40.6	88.0	87.0	85.0	0.74	0.70	0.62	500	150	200	3.35	340
37.0	50.0	2	C180L	2945	64.0	12.2	89.0	88.0	86.0	0.90	0.89	0.86	600	200	250	0.59	205
		4	C200M	1460	67.0	24.7	90.0	89.0	87.0	0.85	0.81	0.73	550	225	275	1.79	260
		6	C225M	970	67.0	37.2	91.0	91.0	89.0	0.85	0.81	0.73	600	170	220	3.35	340
		8	C250S	720	78.0	50.1	89.0	88.0	86.0	0.74	0.70	0.62	500	150	200	5.38	425
45																	

PERFORMANCE DATA

3 - PHASE SPDP SLIPRING INDUCTION MOTOR

VOLTAGE : 415 ± 10% V TYPE : SLIP RING (SR) AMBIENT : 45 DEG C
 FREQUENCY : 50 ± 5% Hz RATING : CONTINUOUS TEMP. RISE (R) : 75 DEG C
 COMBINED : ± 10 % (ABSOLUTE INSULATION : CLASS 'F' REF : IS325,BS4999 & RELEVANT
 VARIATION SUM) PROTECTION : IP21 DUTY :S1 STDS

OUTPUT	P	FRAME SIZE	FL RPM	FLC AMPS.	EFFICIENCY (%)			POWER FACTOR			OC ROTOR VOLTS	ROTOR CURRENT AMPS	GD. ² KGM. ²	NET WT. kg.	PULL OUT TORQUE %FLT
					FL	3/4 LOAD	1/2 LOAD	FL	3/4 LOAD	1/2 LOAD					
3.7	5.0	8 CW160M	700	10	78.0	77.0	75.0	0.68	0.64	0.56	230	9	0.51	130	270
5.5	7.5	6 CW160M	935	14	80.0	79.0	77.0	0.72	0.68	0.60	280	13	0.51	130	270
		8 CW160L	700	14	80.0	79.0	77.0	0.68	0.64	0.56	235	15	0.65	150	270
7.5	10.0	4 CW160M	1410	16	82.0	81.0	79.0	0.82	0.78	0.70	375	12	0.41	130	270
		6 CW160L	935	17	83.0	82.0	80.0	0.72	0.68	0.60	260	19	0.65	150	270
		8 CW180M	705	19	82.0	81.0	79.0	0.68	0.64	0.56	350	13	1.14	200	270
9.3	12.5	4 CW160L	1420	19	83.0	82.0	80.0	0.82	0.78	0.70	380	16	0.53	150	280
		6 CW180M	940	19	83.0	82.0	80.0	0.82	0.78	0.70	300	20	1.14	200	260
		8 CW180L	705	24	82.0	81.0	79.0	0.68	0.64	0.56	345	17	1.45	220	270
11.0	15.0	4 CW160L	1420	22	84.0	82.0	80.0	0.82	0.78	0.70	390	18	0.53	150	280
		6 CW180M	940	23	83.0	82.0	80.0	0.82	0.78	0.70	500	14	1.14	200	260
		8 CW180L	705	27	82.0	81.0	79.0	0.70	0.66	0.58	345	20	1.45	220	270
15.0	20.0	4 CW180M	1420	31	83.0	82.0	80.0	0.82	0.78	0.70	390	23	0.53	150	280
		6 CW180L	945	31	83.0	82.0	80.0	0.82	0.78	0.70	510	18	1.33	220	260
		8 CW200M	720	35	84.0	83.0	81.0	0.71	0.67	0.59	240	40	2.20	275	210
18.5	25.0	4 CW180M	1420	36	84.0	83.0	81.0	0.86	0.80	0.72	480	23	0.91	200	290
		6 CW200M	960	38	86.0	85.0	83.0	0.78	0.74	0.66	515	23	2.20	275	260
		8 CW200L	720	43	84.0	83.0	81.0	0.72	0.68	0.60	235	50	2.20	299	220
22.0	30.0	4 CW180L	1420	42	86.0	85.0	83.0	0.84	0.80	0.72	480	28	1.16	220	300
		6 CW200L	965	46	86.0	85.0	83.0	0.78	0.74	0.66	485	28	2.30	299	280
		8 CW225M	720	49	86.0	85.0	83.0	0.73	0.69	0.61	235	60	3.35	380	210
30.0	40.0	4 CW200M	1440	57	87.0	86.0	84.0	0.84	0.80	0.72	470	39	1.79	275	300
		6 CW225M	965	60	88.0	87.0	85.0	0.78	0.74	0.66	536	35	3.35	380	260
		8 CW225M	720	65	87.0	86.0	84.0	0.74	0.70	0.62	235	80	3.35	380	210
37.0	50.0	4 CW200L	1440	70	87.0	86.0	84.0	0.84	0.80	0.72	430	52	2.11	299	320
		6 CW225M	970	74	89.0	88.0	86.0	0.78	0.74	0.66	536	42	3.35	380	260
		8 CW250S	720	79	89.0	88.0	86.0	0.74	0.70	0.62	465	50	5.70	455	240
45.0	60.0	4 CW225M	1450	82	89.0	88.0	86.0	0.85	0.81	0.73	576	49	2.65	380	320
		6 CW250S	970	88	89.0	88.0	86.0	0.80	0.76	0.68	507	53	5.70	455	230
		8 CW250M	725	95	89.0	88.0	86.0	0.74	0.70	0.62	480	59	6.66	525	250
55.0	75.0	4 CW225M	1460	102	89.0	88.0	86.0	0.84	0.80	0.72	576	59	2.65	380	320
		6 CW250M	975	104	90.0	89.0	87.0	0.82	0.78	0.70	515	65	6.66	525	250
		8 CW280S	730	109	90.0	89.0	87.0	0.78	0.74	0.66	425	79	10.65	635	260
75.0	100.0	4 CW250S	1460	135	90.5	90.0	88.0	0.84	0.80	0.72	505	88	4.77	455	240
		6 CW280S	975	134	91.5	91.0	89.0	0.85	0.81	0.73	300	154	10.09	635	280
		8 CW280M	730	149	90.0	89.0	87.0	0.78	0.74	0.66	535	83	13.44	750	260
93.0	125.0	4 CW250MX	1460	164	92.0	91.0	89.0	0.86	0.82	0.74	500	110	7.15	695	280
		6 CW280M	975	165	92.0	91.0	89.0	0.85	0.81	0.73	360	160	13.44	750	280
		8 CW315S	730	187	91.5	91.0	89.0	0.76	0.72	0.64	490	112	19.16	870	270
110.0	150.0	4 CW280S	1465	193	92.0	91.0	89.0	0.86	0.82	0.74	480	142	9.23	635	280
		6 CW315S	975	197	92.5	92.0	90.0	0.84	0.80	0.72	455	155	17.50	870	300
		8 CW315M	730	218	91.5	91.0	89.0	0.77	0.73	0.65	350	190	21.66	980	270
132.0	175.0	4 CW280M	1475	230	92.5	92.0	90.0	0.86	0.82	0.74	480	167	11.07	750	300
		6 CW315M	975	236	92.5	92.0	90.0	0.84	0.80	0.72	490	173	20.83	980	300
		8 CW315MX	730	256	92.0	91.0	89.0	0.78	0.74	0.66	490	157	26.66	1200	280
160.0	215.0	4 CW315S	1470	279	92.5	92.0	90.0	0.86	0.84	0.76	465	206	14.64	870	300
		6 CW315MX	975	281	93.0	92.0	90.0	0.85	0.81	0.73	530	187	26.66	1200	300
185.0	250.0	4 CW315M	1470	327	92.5	92.0	90.0	0.86	0.82	0.74	540	207	17.43	980	300
200.0	270.0	4 CW315MX	1475	347	93.0	92.0	90.0	0.86	0.82	0.74	540	224	20.91	1200	350
220.0	300.0	4 CW315MX	1475	382	93.0	92.0	90.0	0.86	0.82	0.74	540	246	20.91	1200	310

FL = Full load; FLC = Full Load Current; OC = OPEN CIRCUIT
 NOTE : ALL PERFORMANCE FIGURES ARE SUBJECT TO TOLERANCES AS PER IS325

**SHIPPING SPECIFICATIONS
 THREE PHASE TEFC SQUIRREL CAGE INDUCTION MOTORS
 FOOT MOUNTED**

FRAME SIZE	TYPE OF PACKING	NET WT. (kgs)	GROSS WT. (kgs)	LENGTH (mm)	BREADTH (mm)	HEIGHT (mm)	VOLUME (cu.m.)
ALUMINIUM BODY MOTORS TERMINAL BOX ON TOP							
63	CARTON	5.6	7.5	295	190	230	0.013
71	CARTON	7.0	9.0	295	190	230	0.013
80	CARTON	10.0	13.0	340	230	250	0.019
90S	CARTON	13.0	17.0	400	235	305	0.029
90L	CARTON	16.0	20.0	400	235	305	0.029
100L	CARTON	19.0	24.0	430	265	330	0.038
CAST IRON BODY MOTORS TERMINAL BOX ON TOP							
160M	WOODEN	121	184	826	500	615	0.0254
160L	WOODEN	143	206	826	500	615	0.0254
180M	WOODEN	174	246	930	525	655	0.032
180L	WOODEN	204	276	930	525	655	0.032
200L	WOODEN	254	368	1275	725	790	0.073
225S	WOODEN	350	464	1275	725	790	0.073
225M	WOODEN	380	494	1275	725	790	0.073
250S	WOODEN	460	601	1530	785	890	1.06
250M	WOODEN	500	641	1530	785	890	1.06
280S	WOODEN	620	761	1530	785	890	1.06
280M	WOODEN	700	841	1530	785	890	1.06
315S	WOODEN	1056	1306	1730	1052	1065	1.94
315M	WOODEN	1130	1380	1730	1052	1065	1.94
315L	WOODEN	1200	1480	1830	1102	1115	2.25
355L	WOODEN	2020	2425	1900	1375	1325	3.46
CAST IRON BODY MOTORS TERMINAL BOX ON SIDE							
D80	CARTON	17	21	360	295	245	0.026
D90S	CARTON	22	26	410	310	270	0.034
D90L	CARTON	25	29	410	310	270	0.034
90S	CARTON	22	26	410	310	270	0.034
90L	CARTON	25	29	410	310	270	0.034
100L	CARTON	32	37	465	345	290	0.047
100LX	CARTON	35	40	465	345	290	0.047
112M	CARTON	42	48	495	370	320	0.059
	WOODEN	42	59	525	410	355	0.076
112MX	CARTON	45	51	495	370	320	0.059
	WOODEN	45	62	525	410	355	0.076
132S	CARTON	68	76	600	430	380	0.098
	WOODEN	68	92	625	445	410	0.114
132M	CARTON	79	88	600	430	380	0.098
	WOODEN	79	103	635	445	410	0.114
160M	WOODEN	121	179	826	615	535	0.27
160L	WOODEN	143	204	826	615	535	0.27
180M	WOODEN	174	250	935	715	570	0.38
180L	WOODEN	204	280	935	715	570	0.38
200L	WOODEN	254	366	1025	825	700	0.59
225S	WOODEN	350	462	1025	825	700	0.59
225M	WOODEN	380	492	1025	825	700	0.59
250S	WOODEN	460	586	1150	845	710	0.69
250M	WOODEN	500	628	1150	845		

**SHIPPING SPECIFICATIONS
THREE PHASE TEFC SQUIRREL CAGE INDUCTION MOTORS
FLANGE MOUNTED**

FRAME SIZE	TYPE OF PACKING	NET WT. (kgs)	GROSS WT. (kgs)	LENGTH (mm)	BREADTH (mm)	HEIGHT (mm)	VOLUME (cu.m.)
ALUMNIUM BODY MOTORS - TERMINAL BOX ON TOP							
63D	CARTON	5.6	7.5	295	190	230	0.012
71D	CARTON	7.0	9.0	295	190	230	0.012
80D	CARTON	10.0	13.0	340	230	250	0.02
90SD	CARTON	13.0	17.0	400	235	305	0.029
90LD	CARTON	16.0	20.0	400	235	305	0.029
100LD	CARTON	19.0	24.0	430	265	330	0.038
CAST IRON BODY MOTORS - TERMINAL BOX ON SIDE							
D80D	CARTON	19	23	360	295	250	0.027
D90SD	CARTON	24	29	410	310	270	0.034
D90LD	CARTON	27	32	425	310	270	0.034
90SD	CARTON	24	29	410	310	270	0.034
90LD	CARTON	27	32	410	310	270	0.034
100LD	CARTON	34	39	465	345	290	0.047
100LXD	CARTON	37	42	465	345	290	0.047
112MD	CARTON	45	51	495	370	320	0.059
	WOODEN	45	72	555	445	405	0.100
112MXD	CARTON	48	54	495	370	320	0.0562
	WOODEN	48	75	555	445	405	0.1000
132SD	CARTON	71	79	600	430	380	0.098
	WOODEN	71	108	660	490	465	0.1504
132MD	CARTON	82	91	600	430	380	0.098
	WOODEN	82	119	762	442	407	0.137
160M	WOODEN	127	204	900	655	610	0.36
160L	WOODEN	148	225	900	655	610	0.36
180M	WOODEN	181	258	900	655	610	0.36
180L	WOODEN	215	292	900	655	610	0.36
200L	WOODEN	258	406	1142	885	839	0.84
225S	WOODEN	363	511	1142	885	839	0.84
225M	WOODEN	393	541	1142	885	839	0.84
250S	WOODEN	467	705	992	902	1246	1.11
250M	WOODEN	507	745	992	902	1246	1.11
280S	WOODEN	620	898	1072	1072	1431	1.64
280M	WOODEN	700	978	1072	1072	1431	1.64
315S	WOODEN	1086	1424	1280	1210	1545	2.39
315M	WOODEN	1160	1498	1280	1210	1545	2.39
315L	WOODEN	1200	1624	1850	1450	1275	3.42
355L	WOODEN	2020	2300	1850	1450	1275	3.42

**SHIPPING SPECIFICATIONS
THREE PHASE TEFC SLIPRING INDUCTION MOTORS
FOOT MOUNTED TB ON TOP**

FRAME SIZE	TYPE OF PACKING	NET WT. (kgs)	GROSS WT. (kgs)	LENGTH (mm)	BREADTH (mm)	HEIGHT (mm)	VOLUME (cu.m.)
160M	WOODEN	141	243	1065	570	680	0.413
160L	WOODEN	165	267	1065	570	680	0.413
180M	WOODEN	205	307	1065	570	680	0.413
180L	WOODEN	235	337	1065	570	680	0.413
200L	WOODEN	285	393	1275	725	790	0.73
225S	WOODEN	380	488	1275	725	790	0.73
225M	WOODEN	410	518	1275	725	790	0.73
250S	WOODEN	500	633	1450	785	890	1.06
250M	WOODEN	540	673	1530	785	890	1.06
280S	WOODEN	670	803	1530	785	890	1.06
280M	WOODEN	750	883	1530	785	890	1.06
315S	WOODEN	1106	1346	1730	1052	1065	1.94
315M	WOODEN	1180	1420	1730	1052	1065	1.94
315L	WOODEN	1260	1530	1830	1102	1115	2.24
355L	WOODEN	2150	2445	1900	900	1150	1.96

**SHIPPING SPECIFICATIONS
THREE PHASE TEFC SLIPRING INDUCTION MOTORS
FOOT MOUNTED TB ON SIDE**

FRAME SIZE	TYPE OF PACKING	NET (kgs)	GROSS WT. (kgs)	LENGTH (mm)	BREADTH (mm)	HEIGHT (mm)	VOLUME (cu.m.)
132S	WOODEN	88	126	820	600	500	0.52
132M	WOODEN	111	149	820	600	500	0.52
160M	WOODEN	141	243	980	800	673	0.52
160L	WOODEN	165	267	980	800	673	0.52
180M	WOODEN	205	311	980	800	673	0.52
180L	WOODEN	235	341	980	800	673	0.52
200L	WOODEN	285	423	1150	870	738	0.74
225S	WOODEN	380	518	1150	870	738	0.74
225M	WOODEN	410	548	1150	870	738	0.74
250S	WOODEN	500	638	1300	915	745	0.89
250M	WOODEN	540	678	1300	915	745	0.89
280S	WOODEN	670	884	1500	1067	850	1.36
280M	WOODEN	750	964	1500	1067	850	1.36
315S	WOODEN	1106	1359	1730	1170	930	1.88
315M	WOODEN	1180	1433	1730	1170	930	1.88
315L	WOODEN	1260	1613	1730	1170	930	1.88
355L	WOODEN	2150	2445	1900	1220	1016	2.35

**SHIPPING SPECIFICATIONS
THREE PHASE SLIP RING TEFC INDUCTION MOTORS FLANGE MOUNTED**

FRAME SIZE	TYPE OF PACKING	NET WT. (kgs)	GROSS WT. (kgs)	LENGTH (mm)	BREADTH (mm)	HEIGHT (mm)	VOLUME (cu.m.)
DW132S	WOODEN	88	126	820	600	550	0.27
DW132M	WOODEN	111	149	820	600	550	0.27
NDW160M	WOODEN	141	243	1165	710	700	0.58
NDW160L	WOODEN	165	267	1165	710	700	0.58
NDW180M	WOODEN	205	307	1165	710	700	0.58
NDW180L	WOODEN	235	337	1165	710	700	0.58
NDW200L	WOODEN	285	393	1275	725	790	0.73
NDW225S	WOODEN	380	488	1275	725	790	0.73
NDW225M	WOODEN	410	518	1275	725	790	0.73

**SHIPPING SPECIFICATIONS
THREE PHASE SPDP SQUIRREL CAGE INDUCTION MOTORS
FOOT MOUNTED**

FRAME SIZE	TYPE OF PACKING	NET WT. (kgs)	GROSS WT. (kgs)	LENGTH (mm)	BREADTH (mm)	HEIGHT (mm)	VOLUME (cu.m.)
160M	WOODEN	121	192	826	615	535	0.27
160L	WOODEN	131	202	875	705	585	0.27
180M	WOODEN	185	291	1023	826	696	0.59
180L	WOODEN	205	311	1023	826	696	0.59
200M	WOODEN	260	366	1023	826	696	0.59
200L	WOODEN	300	406	1023	826	696	0.59
225M/MX	WOODEN	340	446	1023	826	696	0.59
250S	WOODEN	425	563	1306	1030	745	1.00
250M	WOODEN	480	618	1306	1030	745	1.00
280S	WOODEN	620	834	1500	1067	850	1.36
280M	WOODEN	710	924	1500	1067	850	1.36
315S	WOODEN	865	1118	1730	1170	930	1.88
315M	WOODEN	950	1203	1730	1170	930	1.88
315MX	WOODEN	1150	1403	1730	1170	930	1.88

**SHIPPING SPECIFICATIONS
THREE PHASE SPDP SQUIRREL CAGE INDUCTION MOTORS FLANGE MOUNTED**

FRAME SIZE	TYPE OF PACKING	NET WT. (kgs)	GROSS WT. (kgs)	LENGTH (mm)	BREADTH (mm)	HEIGHT (mm)	VOLUME (cu.m.)
160M	WOODEN	130	202	796	620	591	0.29
160L	WOODEN	140	212	796	620	591	0.29
180M	WOODEN	195	267	846	756	656	0.42
180L	WOODEN	215	287	846	756	656	0.42
200L	WOODEN	310	452	1142	810	839	0.78
225M	WOODEN	360	502	1142	810	839	0.78
250M	WOODEN	495	725	992	902	1246	1.14
280M	WOODEN	725	991	1162	1012	1296	1.52
315M	WOODEN	980	1308	1282	1212	1546	2.39

**SHIPPING SPECIFICATIONS
THREE PHASE SPDP SLIP RING INDUCTION MOTORS
FOOT MOUNTED**

FRAME SIZE	TYPE OF PACKING	NET WT. (kgs)	GROSS WT. (kgs)	LENGTH (mm)	BREADTH (mm)	HEIGHT (mm)	VOLUME (cu.m.)
160M	WOODEN	130	201	926	715	587	0.39
160L	WOODEN	150	221	926	715	587	0.39
180M	WOODEN	200	306	1023	826	696	0.59
180L	WOODEN	220	326	1023	826	696	0.59
200L	WOODEN	300	419	1150	845	711	0.69
225M	WOODEN	380	518	1306	1030	745	0.90
250S	WOODEN	455	593	1306	1030	745	0.90
250M	WOODEN	525	663	1306	1030	745	0.90
250MX	WOODEN	695	948	1500	1067	850	1.36
280S	WOODEN	635	888	1500	1067	850	1.36
280M	WOODEN	750	1003	1730	1170	850	1.36
315S	WOODEN	870	1123	1730	1170	930	1.88
315M	WOODEN	980	1233	1730	1170	930	1.88
315MX	WOODEN	1200	1453	1730	1170	930	1.88

NOTE : As the design and manufacture of Crompton Greaves electrical equipment are subject to constant improvement,, the product supplied may differ in some details from the specifications and illustrations given in this booklet.

Northern Region Sales Office :

New Delhi:
Vandana, 11 Tolstoy, Marg, New Delhi - 110 001
Phones:(011)3721537, 3312377
Jalandhar :
50, Mahavir Marg, Jalandhar - 144 001
Phones: (0181) 223801
Lucknow:
Saran Chambers II, 3rd Floor, 5 Park Road,
Lucknow - 226 001
Phones:(0522) 239443
Jaipur:
Church Road, P. O. Box. No.: 173, Jaipur-302 001
Phones:(0141) 376919, 376307

Eastern Region Sales Office :

Calcutta :
50, Chowringhee Road, Calcutta - 700 071
Phones: (033) 2829681, 2822132
Bhubaneshwar:
Janpath Tower, Third Floor, Ashok Nagar,
Unit II, Bhubaneshwar - 751 009
Phones:(0674)531128

Western Region Sales Office :

Mumbai :
Kanjur Marg (E), Mumbai-400 042.
Tel.: (022) 5782451, 5794882
Ahmedabad :
90, Sakar II, Opp. Town Hall, Ellis Bridge,
Ahmedabad - 380 006
Phones: (079) 6581729, 6587328
Pune:
Surya Bhavan, 5th Floor, Fergusson College Road,
Pune-411 005
Phones: (020) 5535675.
Indore :
1038, Apollo Trade Centre, 2B, Rajgarh Kothi
Mumbai-Agra Road,Indore - 452 001.
Phones : (0731) 498269
Nagpur:
3, West High Court Road, Lal Bahadur Shastri Chowk,
Dharampeth, Nagpur - 440 010
Phones: (0172) 530537

Southern Region Sales Office :

Chennai :
No.3-A, Kodambakkam High Road,
Nungambakkam,
Chennai - 600 034.
Phones:(044)8257375
Bangalore :
4/02, Lakshmi Mansion, Ground Floor, 22nd Cross,
8th Main,
Jayanagar 3rd Block, Bangalore - 560 011.
Phones: (080) 6533926
Cochin :
Cherupushpam Building, 5th Floor, 330-6
Shanmugham Road, Ernakulum,Cochin - 682 031.
Phones: (0484) 370860
Secunderabad:
4th Floor, Minerva Complex, 94, Sarojini Devi Road,
Secunderabad - 500 003.
Phones:(040)7847090

Regional Service Centres:

North: 27, Rani Jhansi Road, New Delhi-110 055 Phones: (011) 7516993
East: 171/1A, 'Acharya', J. C. Bose Road, Kolkata-700 014 Phones: (033) 2441557
West: Mathuradas Mills Compound, Next to Milton, Lower Parel (W), Mumbai-400 013 Phones: (022) 4922572.
South: 3A, Kodambakkam High Road, Nunbakkam, Chennai-600 034 Phones : (044) 8274610

INDUCTION MOTORS

FRAME 63 TO 355

LOW TENSION TEFC & SPDP
INDUCTION MOTORS



INDUCTION
MOTORS

INDU
MOT



**Crompton
Greaves**

EVERYDAY SOLUTIONS

Regd Office : CG House, 6th Floor, Dr. Annie Besant Road, Prabhadevi, Mumbai - 400 025

Tel.: (022) 423 7777. Fax : (022) 438 2288

Manufacturing Units:

Goa Works :

D-2/21/22/23, Tivim Industrial Estate, Karaswada, Bardez, Goa - 403 526.

Tel.: (0832) 257409, 257639 Fax: (0832) 257207

Ahmednagar Works:

A-6/2, M.I.D.C. Industrial Area, Ahmednagar - 414111

Tel.: (0241) 2777507, 2777372. Fax : (0241) 2777508

LTM/AUG02/1000